

THE FACADE COLLECTION

2025

HAUZEN
studio



FACADES VENEERED

VISUALISATION MATERIALS:

Milling: Aster 130

Carcass: Chipboardlam.Egger H3317 Cuneo oak brown ST28 NEW

Facades: Oak lamella, MDF Painted NCS S 5020-R90B

Worktop and backsplash: NEOLITH porcelain stoneware
Mont Blanc Silk 12 mm 3200×1600

MILLING AIREY 74

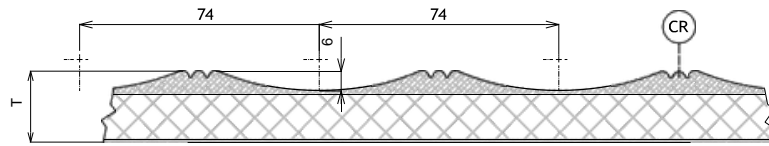

MILLING ASTER 130

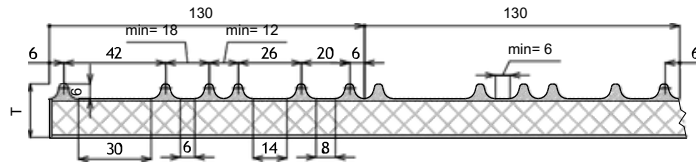

MILLING BRIGHT 12

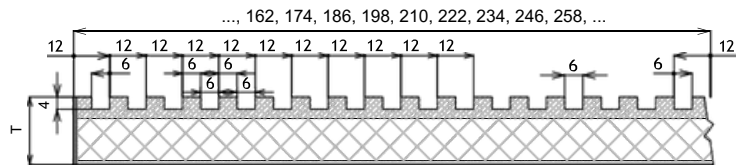

MILLING NERO 100

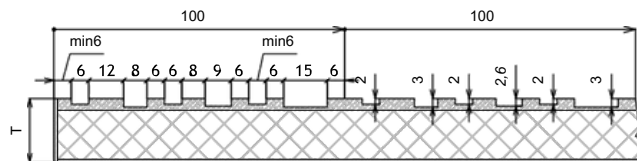

MILLING WAVES 17

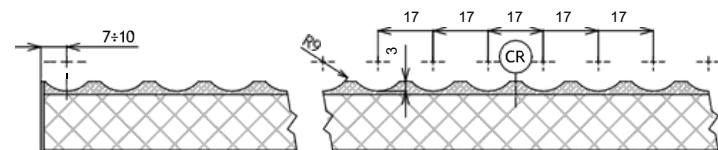

FACADES VENEERED

IMAGING MATERIALS:

Milling: Cave 28.5

Carcass: Chipboardlam. Egger U899 Space
grey (pale black) ST9

Facades: Oak lamella, chipboard FENIX NTM 0720
Ingram Black / 0509 Arpa (1st grade)

Worktop and apron: NEOLITH ClasStone Layla

Slate

12 mm 3200×1600 porcelain stoneware

•Handle Marella M 15192.160 titanium



MILLING CAVE 12

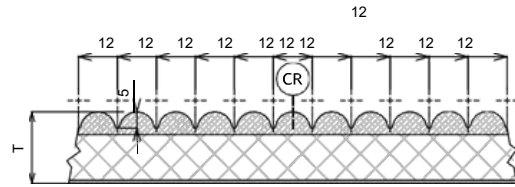

MILLING CAVE 14

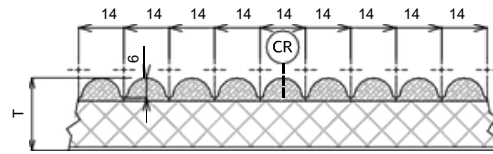

MILLING CAVE 17

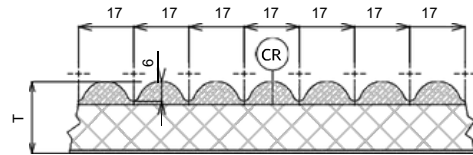

MILLING CAVE 20

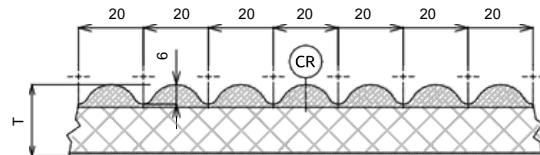

MILLING CAVE 28

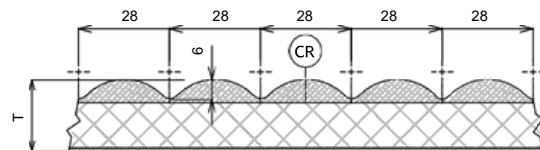

FACADES VENEERED

IMAGING MATERIALS:

Milling: Flores55

Carcass: Chipboard lam. Kronospan K096 SU Clay

Grey

Facades: Ash lamella, FENIX NTM 0748 Arizona
Beige / 0616 Arpa chipboard (1st grade)

•Worktop and backsplash: NEOLITH ClasStone
Colorado Dunes Silk 12 mm 3200×1600 porcelain
stoneware

•Handle U 9.5 m, black super matt



MILLING NEVIS 19

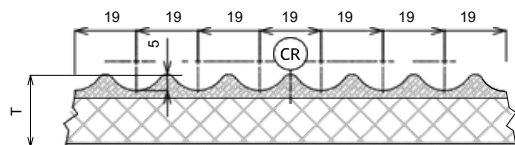

MILLING NEVIS 24

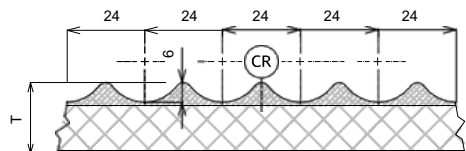

MILLING NEVIS 28

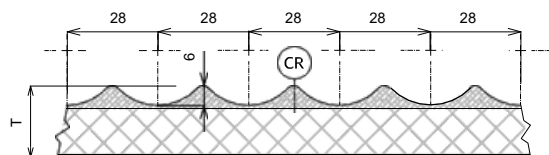

MILLING FLORES 45

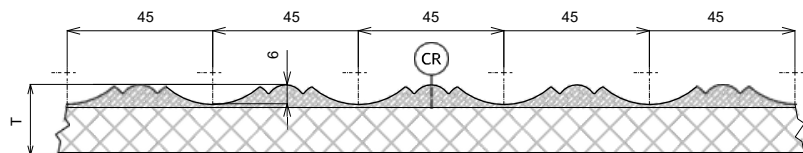

MILLING FLORES 55

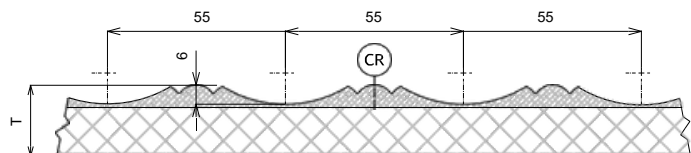

FACADES VENEERED

IMAGING MATERIALS:

Milling: Sunset 15

Body: Chipboard lam. Egger U708 Light grey
(smoke grey) ST9 /RO/ /RO/

•Facades: Oak lamella, chipboard lam. Egger U699
Green spruce ST9 NEW

•Worktop and apron: Fenix NTA 5000 compact slab
Hamilton steel black core

Handle: Mortise and tenon professional handle Ferro Fiori M 8040
silver anodised, 19 mm,
Mortise professional handle Ferro Fiori M 8060
silver anode, 19 mm



MILLING SUNSET 15

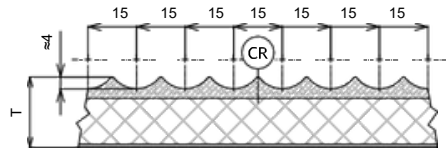

MILLING SUNSET 20

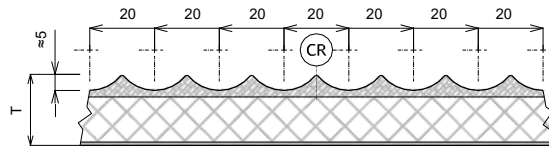

MILLING SUNSET 24

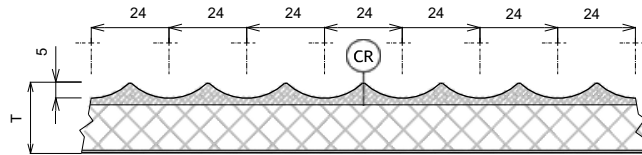

MILLING SUNSET 64

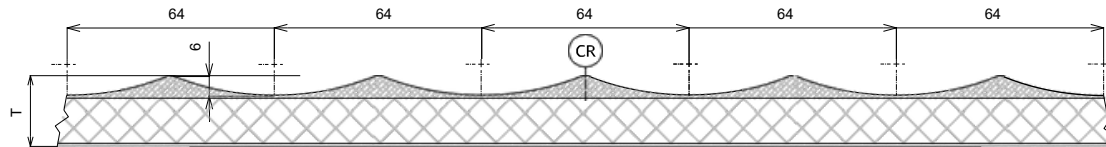

MILLING LIBERTY 114

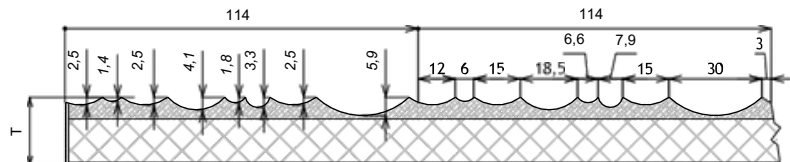

FACADES VENEERED

IMAGING MATERIALS:

- Milling: Emmy32
- LamellaAmerican walnut facades,
MDF Painted RAL 7024
- Worktop and backsplash: Inalco Brazza
Crema
porcelain stoneware 12 mm
3200×1600
- Handle: UKW 4, 18 mm, 5 m, black super
matt, mortise professional handle



MILLING FANCY 24

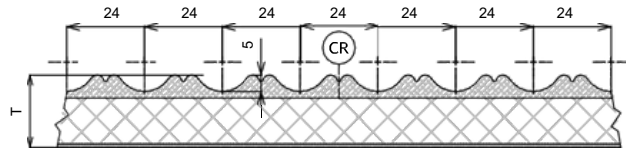

MILLING FANCY 29

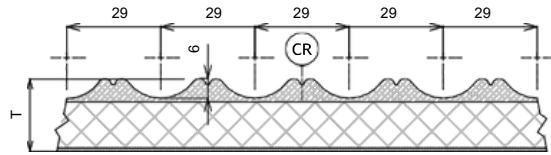

MILLING FANCY 33

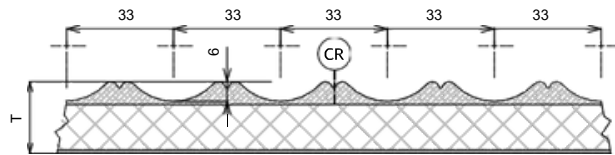

MILLING FANCY 69

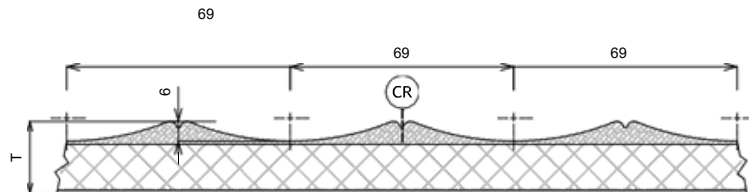

MILLING EMMI 32

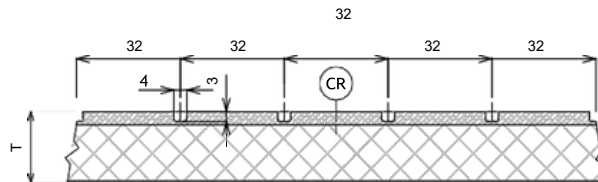



FACADES VENEERED

VISUALISATION MATERIALS:

- Colour: Classic Tangent Oak.
- Ferro Fiori M0030.256pen,black/art.146949
- Worktop ARPA 3329MIKAwaterproof/art.146849



Classic radial oak veneer

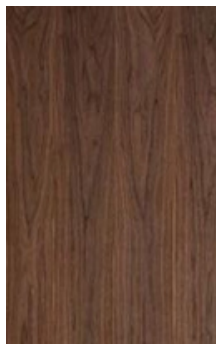

American walnut veneer tangent

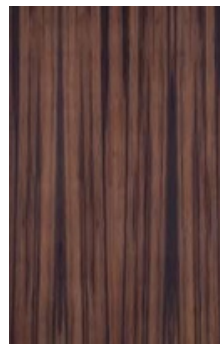

ALPI mahogany veneer



White Oak veneer
18.50 ALPI



Lauro Preto veneer
ALPI

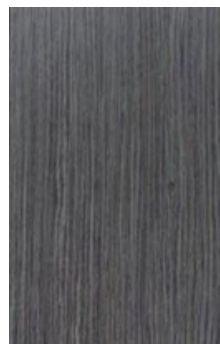

Smoky grey oak veneer
10.65 ALPI





VENEERED FACADES

FACADES VENEERED

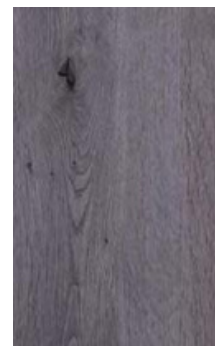

European Oak veneer
Rough Cut 3D
ALPI



Veneer Walnut
XILO
tangential
10.11 ALPI



Sucupira veneer
ALPI



Wood Contur veneer Oak
classic tangential

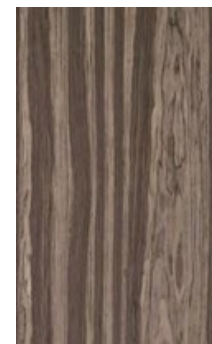

ALPI Aged American
walnut veneer

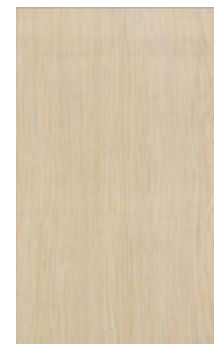

Planked Oak veneer
12.96 ALPI



Wavy American Walnut veneer
12.19 ALPI



Grey oak veneer
18.23 ALPI

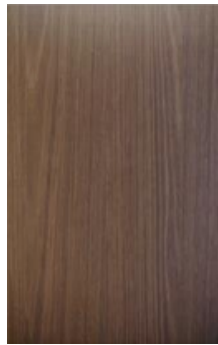

Walnut veneer
10.95 ALPI

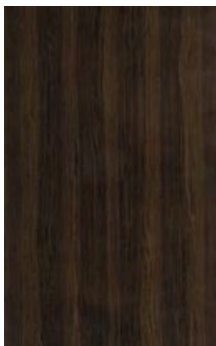

Smoky oak veneer
12.85 ALPI



Noble walnut veneer
ALPI

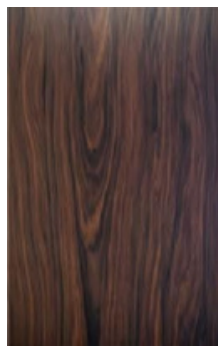

Polysander veneer
ALPI



FACADES ASSEMBLED PAINTED

VISUALISATION MATERIALS:

- Colour:RAL 9003
- Milling: Model1
- Marella pen M 15232.128 nickel polished / art. 83723
- Pen Marella M 24232.30 nickel polished / art. 83725
- Caesarstone 5141 Frosty Carrina quartzite worktop 20 mm



MILLING MODEL 1

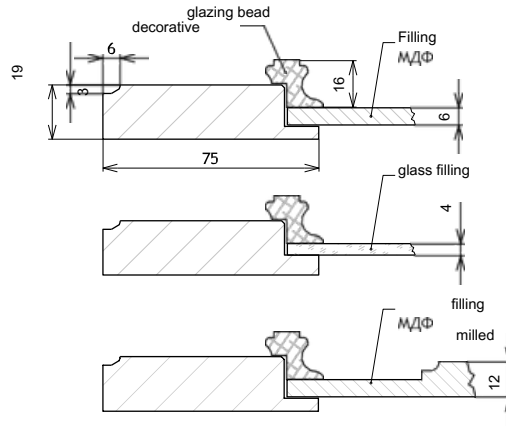

MILLING MODEL 2

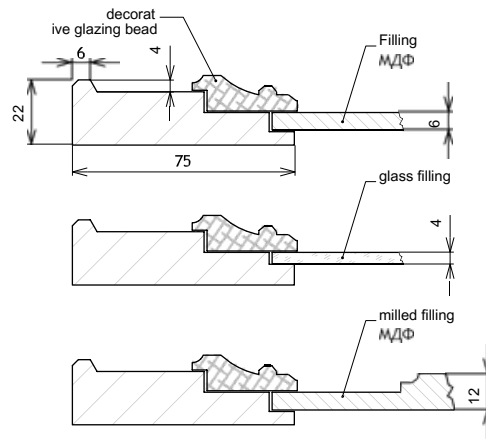

MILLING MODEL 3

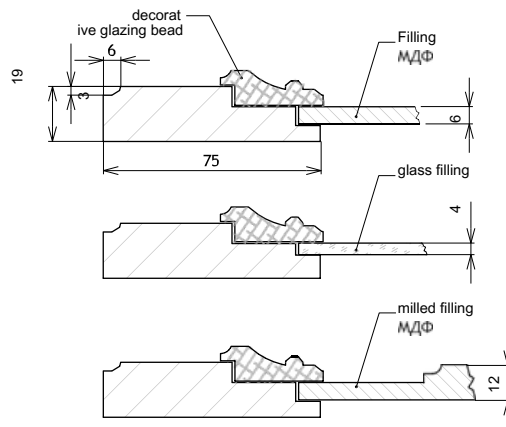

FACADES PAINTED

Collection "Variety of lines"

MATERIALS FROM THE VISUALISATION:

- Colour: VMA0307310
- Milling: Nevis 19
- Worktop Inalco Azalai Negro natural granite 12 mm
- Apron: Inalco Azalai Negro natural porcelain stoneware 4 mm



MILLING EMMI 32

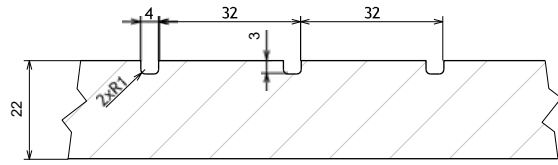

MILLING KOS 21

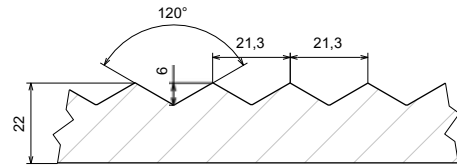

MILLING NEVIS 19

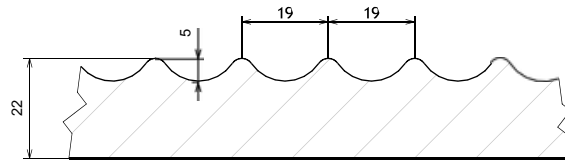

MILLING SANSET 15

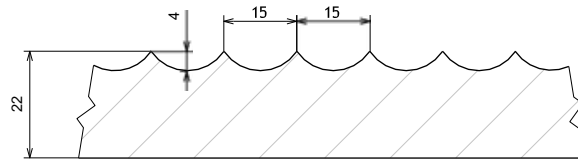

MILLING FANCY 24

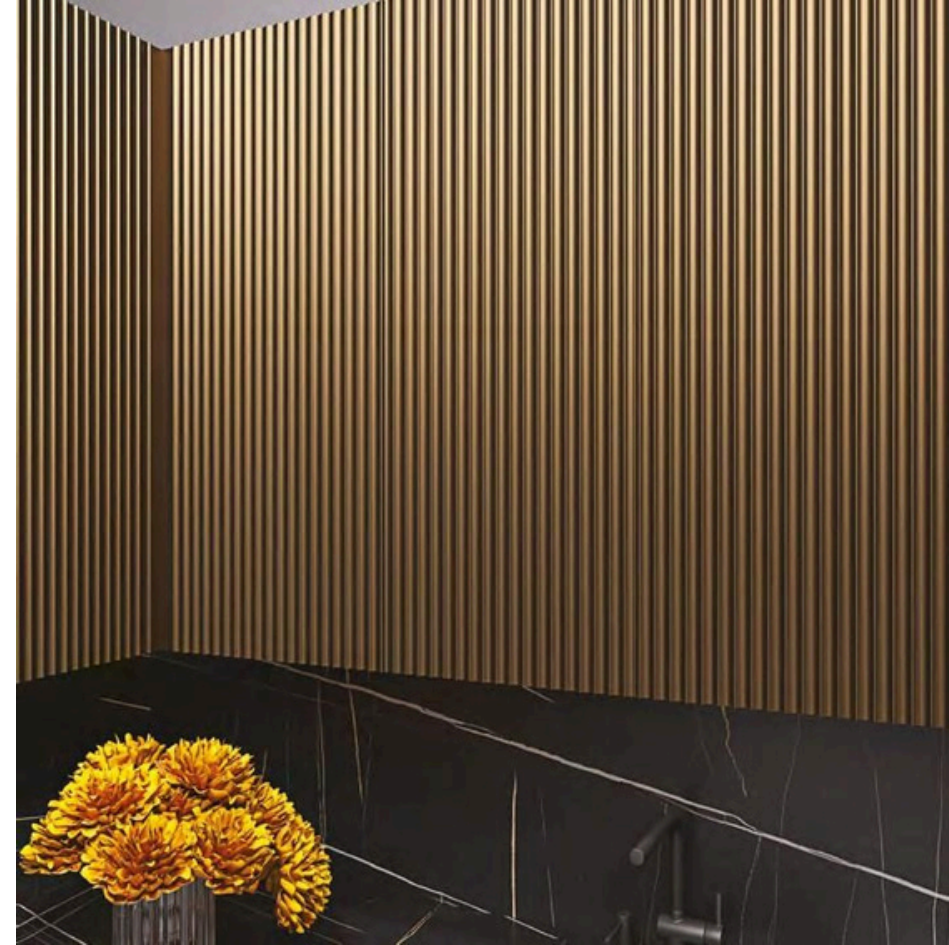
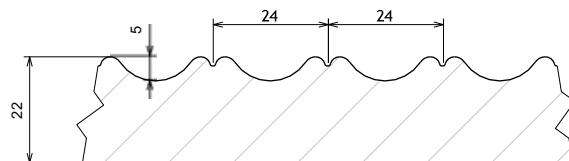

FACADES PAINTED

Collection "Variety of lines"

VISUALISATION MATERIALS:

- Colour:RAL 9016
- Milling: Aster
- Handle RE 1006/320 (DR 10/320 G5) Nickel / art. 80804
- Handle RE 1006/160 (DR 10/160 G5) Nickel /art. 80800
- Worktop Tangential oak veneer 38 mm
- Backsplash: Inalco Iseo Gris abujardado porcelain stoneware 4 mm



MILLING ASTER 130

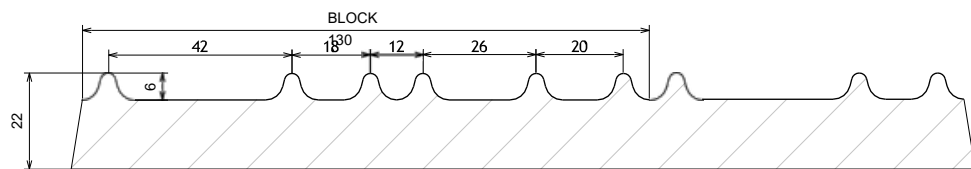

MILLING NEVIS 24

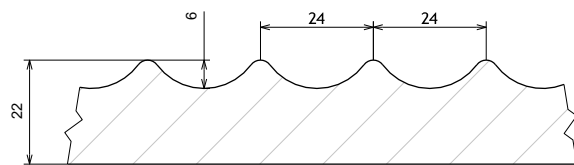

MILLING SUNSET 20

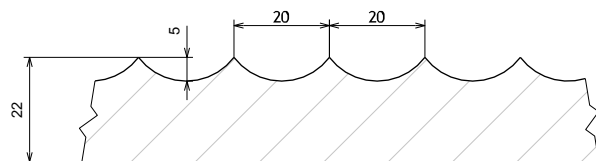

MILLING FANCY 29

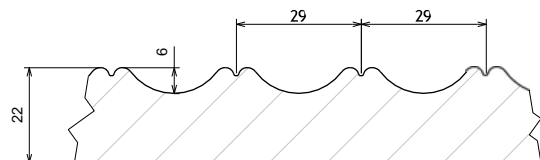

MILLING NEVIS 28

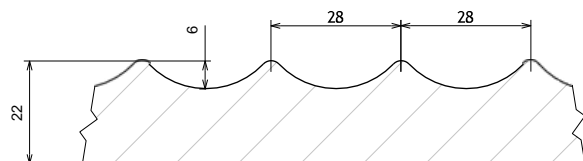



FACADES PAINTED

Collection "Variety of lines"

MATERIALS FROM THE VISUALISATION:

- Colour: NCS 1515-R20B
- Milling: Airey 74
- Worktop Acrylic stone
Getacore GC 4410 Concrete Riva

MILLING SUNSET 24

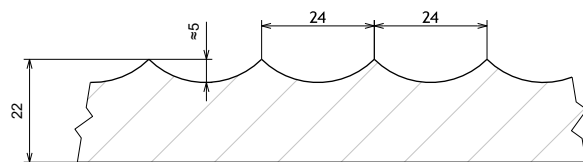

MILLING FANCY 33

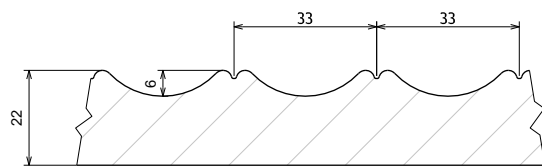

MILLING SUNSET 64

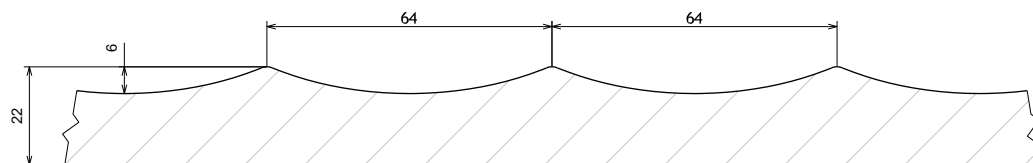

MILLING FANCY 69

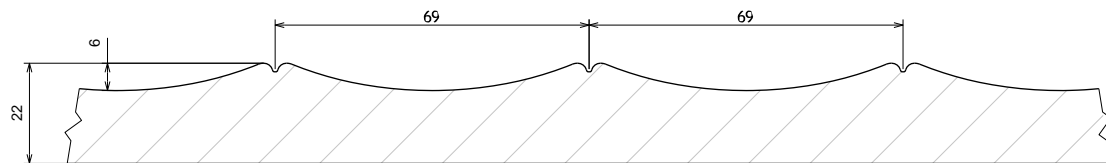

MILLING AIRI 74

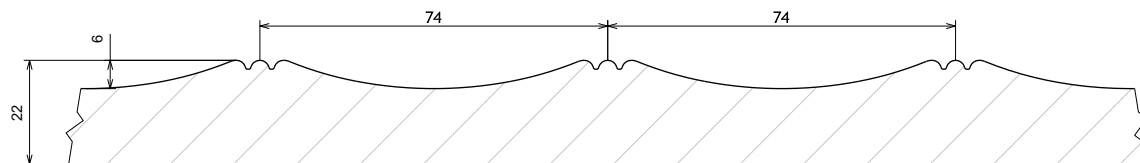

FACADES PAINTED

FACADES PAINTED

Collection "Variety of lines"

VISUALISATION MATERIALS:

- Colour: NCS 1005-Y50R
- Milling: Flores 55
- Worktop Acrylic stone Grandex Adventure
A-418 Oak Wood 12 mm
- Backsplash: NEOLITH ClasStone
Calacatta 01R silk 6 mm



MILLING FLORES 55

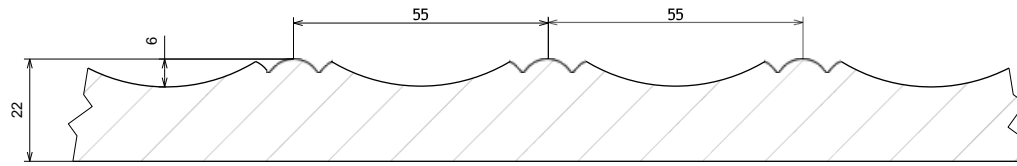

MILLING FLORES 45

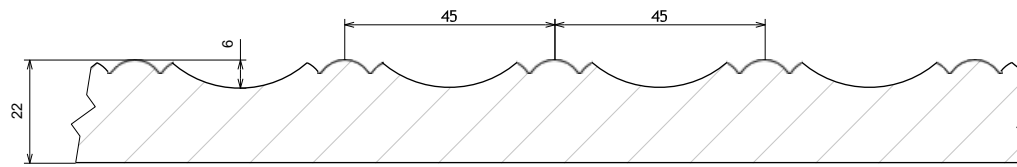

MILLING NERO 100

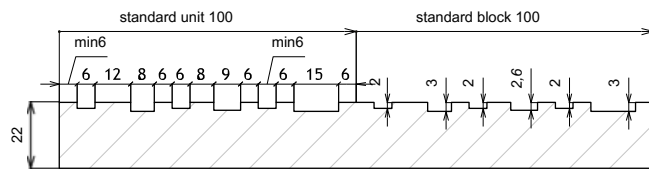

MILLING BRIGHTON 12

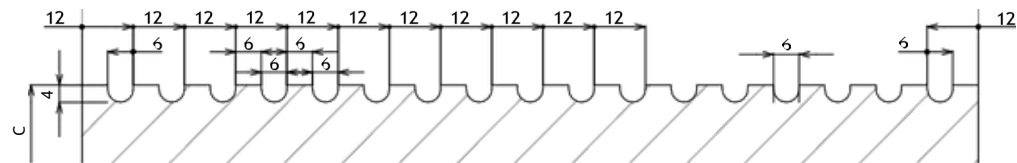

MILLING LIBERTY 114

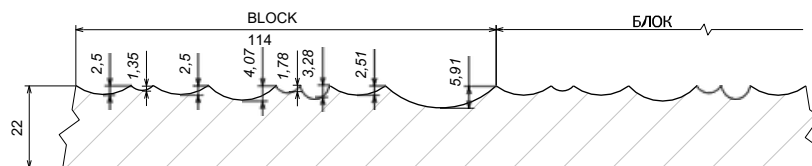

FACADES PAINTED

Collection "Variety of lines"

VISUALISATION MATERIALS:

- Colour: NCS 1010-Y60R
- Milling: Liberty
- Handle Cosma M 12951.192 steel / art. 21819
- Worktop Acrylic stone Getacore GC 2388 Miracle Beach 10 mm
- Backsplash: Inalco Petra porcelain stoneware
- Crema abujardado 4 mm



MILLING CAVE 12

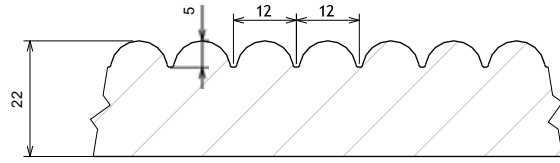

MILLING CAVE 14

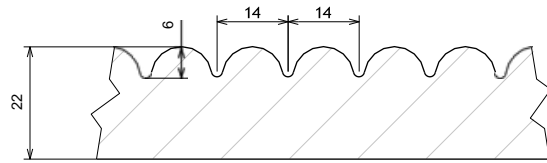

MILLING CAVE 17

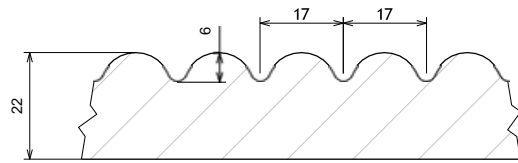

MILLING CAVE 20

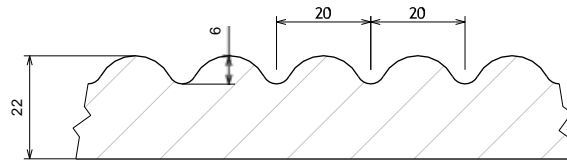

CAVE MILLING 28.5

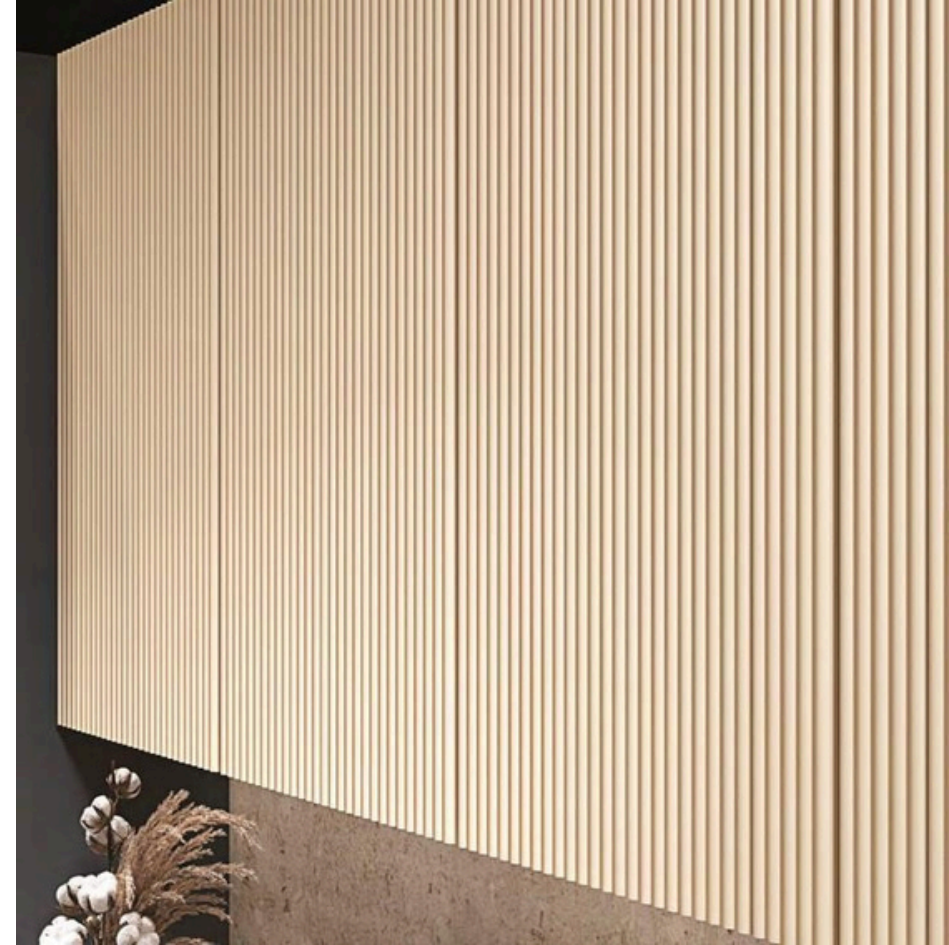
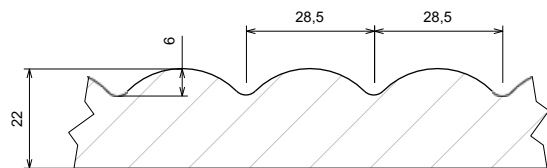

FACADES PAINTED

VISUALISATION MATERIALS:

- Colour: NCS S 4005Y20R
 - Milling: Alba
- Pen Marella M 15194.160 graphite /art. 69687
- Pen Marella M 15194.320 graphite /art. 69690
 - Kronospan K218 GG Andromeda worktop
Black 38 mm /art. 152899
- Skinali (6 mm diamond on the glass) /art. 49756



MILLING ALBA



RAL 9003



RAL 9001



RAL 9016



RAL 7036



RAL 9010



WCP 115

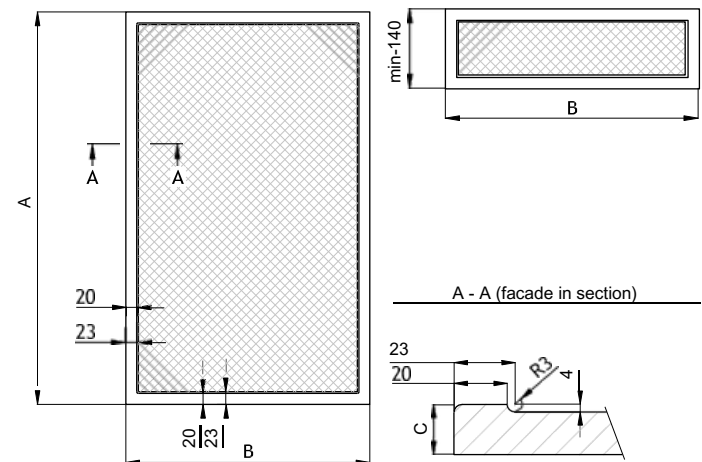

FACADES PAINTED

FACADES PAINTED

VISUALISATION MATERIALS:

- Colour:RAL7043TransportgreyB
 - Milling: Geometry
 - Handle 224-160 black / art. 91303
- Egger F117/ST76/R3-1U worktop Ventura black 38 mm /art. 147896
- Backsplash: MDF Fenix NTM 0751 Jaipur /art. Arpa 0759 10 mm /art. 62123



MILLING GEOMETRY



RAL 9002



RAL 7045



RAL 1013



RAL 7024



RAL 1015



RAL 7004

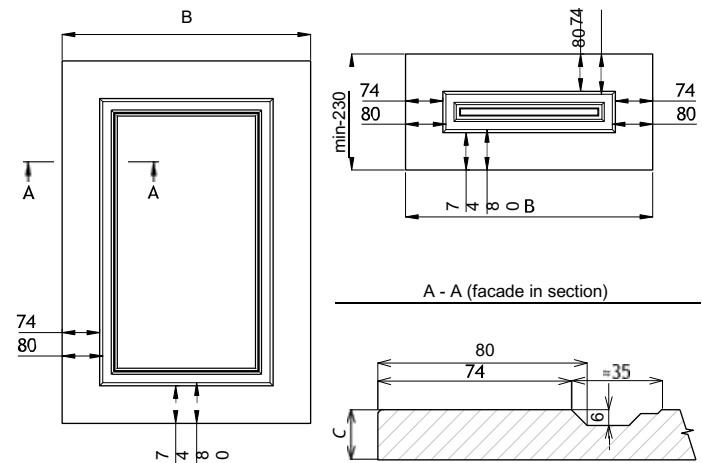

FACADES PAINTED

FACADES PAINTED

MATERIALS ON VISUALISATION:

- Colour: WCP 148
- Milling: Glory
- Cosma M 12749.320 nickel matt pen / art. 21844
- Cosma M 12748.160 nickel brushed / art. 21842
- Worktop: Acrylic sheet Corian Getacore GC 4411 Concrete Riva
- Backsplash: MDF Fenix NTM Bloom 0771 / Fenix NTM Bloom 0771 19 mm / art. 115723



MILLING GLORY



RAL 9005



RAL 7037



RAL 7012



RAL 7040



RAL 1019



WCP 127

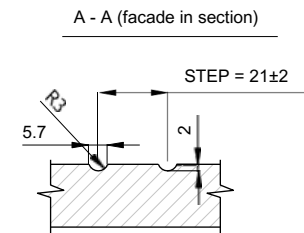
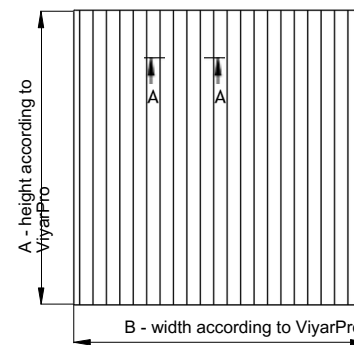
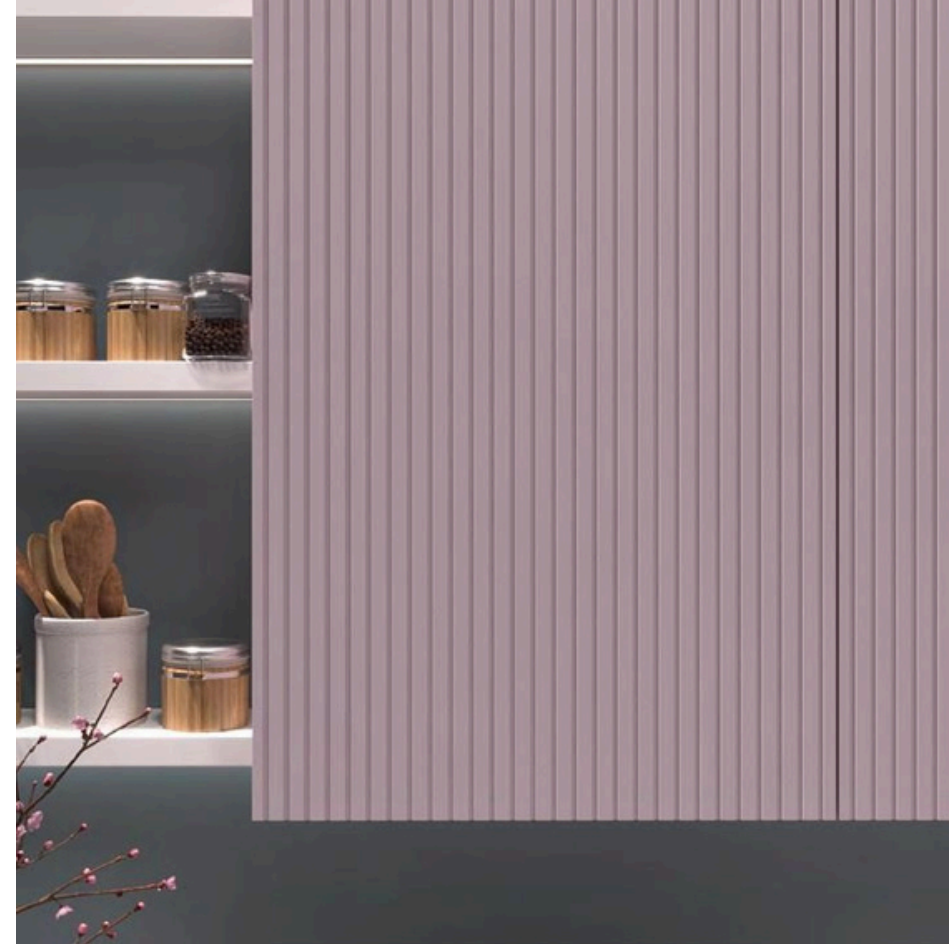

FACADES PAINTED

FACADES PAINTED

VISUALISATION MATERIALS:

- Colour: NCS S 0804Y30R
- Milling: Grace
- GOLA horizontal profile Ferro Fiori, L=4100 mm, type L nickel brushed / art. 72558
- GOLA horizontal profile Ferro Fiori with LED groove, L=4100 mm, type C, nickel brushed / art. 117884
- Worktop: MDF Arpa 3447 Ker 19 mm /art. 111176
- Backsplash: MDF Arpa 3447 Ker 10 mm /art. 84210



MILLING GRACE



WCP 176



WCP 83



NCS S 2005Y50R



RAL 7016



RAL 7044



NCS S 1000N

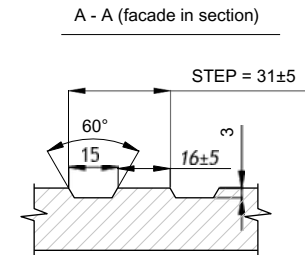
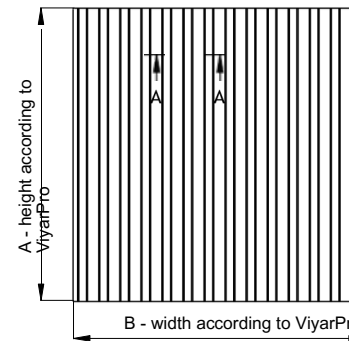

FACADES PAINTED

MATERIALS FROM THE VISUALISATION:

- Colour:RAL7031 Blue-grey
 - Milling: Country
- Marellahandle M 15244.320
nickel / art. 34617
- Worktop Kronospan 4298 UE Atelier
Light 38 mm /art. 152871
- Backsplash: Kronospan 4298 SU chipboard Atelier
Light 18 mm /art. 28717



MILLING COUNTRY



NCS S 0300N



NCS S 0500N



RAL 1000



RAL 7046

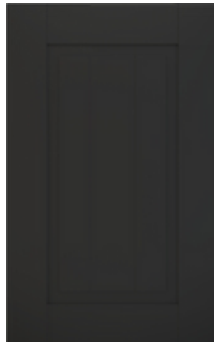

RAL 7043



RAL 6005

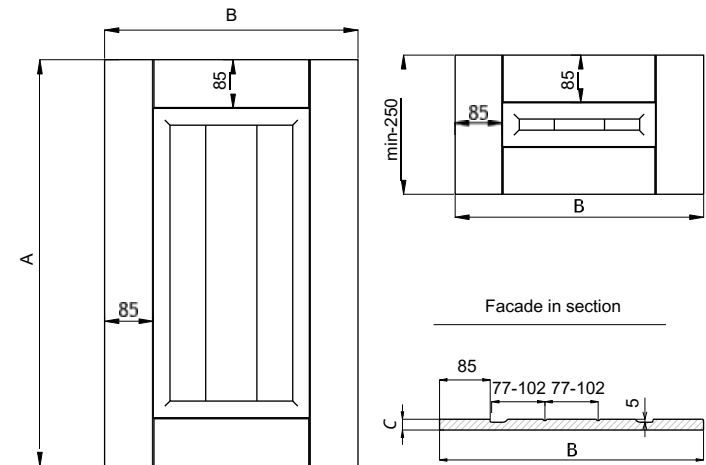

FACADES PAINTED

FACADES PAINTED

VISUALISATION MATERIALS:

- Colour: RAL 9003 Signal white
- Milling: Classic
- Pen Ferro FioriD4440.160antique silver / art.115334
- Ferro Fiori D 4440.224antiquesilver handle /art.115337
- Worktop:Acrylicsheet CorianGetacore
GC 2252 FrostedCarat



MILLING CLASSIC



RAL 7035



NCS S 2002Y50R



RAL 7042



RAL 7011



RAL 5014

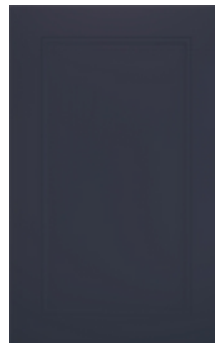

RAL 7015

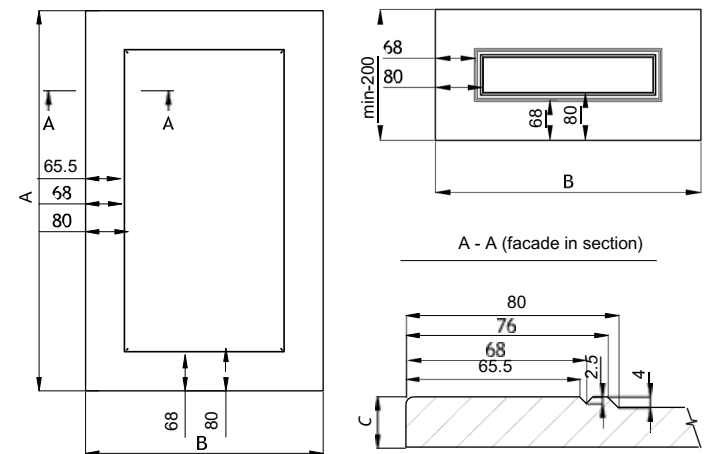

FACADES PAINTED

FACADES PAINTED

VISUALISATION MATERIALS:

- Colour: NCS S 7000N
- Milling: Costa
- MarellaCL 15231.160 handle
antique silver / art. 46455
- Worktop: Corian Getacore GC 1472
Miracle Stone acrylic sheet



MILLING COSTA



NCS S 1002Y50R



WCP 67



RAL 6034



RAL 5023



RAL 5024



RAL 7021

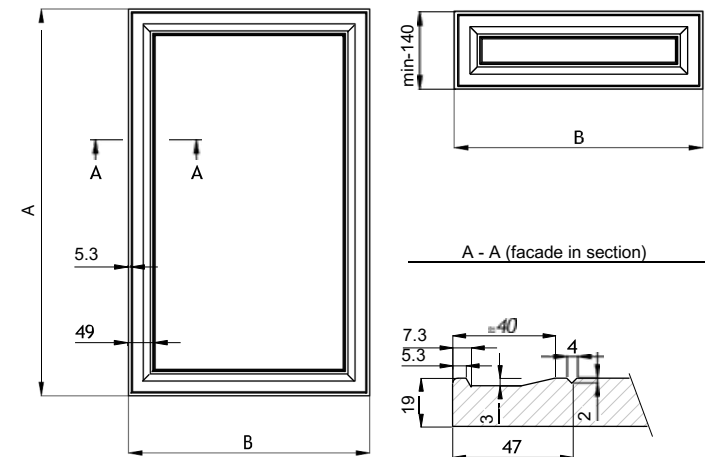

FACADES PAINTED



FACADES PAINTED

VISUALISATION MATERIALS:

- Colour:RAL7024Graphite grey
 - Milling: Loft

- Ferro Fiori M 0220.192 handle
black brush / art. 11482

Egger H3133 ST12 R3-1U worktop

Davos oak truffle 38 mm /art. 147934

Apron: Ricci 6019 AR/6133 AR 2-sided

- chipboard wall panel 14 mm /art. 126888

MILLING LOFT



NCS S 2500N



RAL 7032



NCS S 2005Y60R

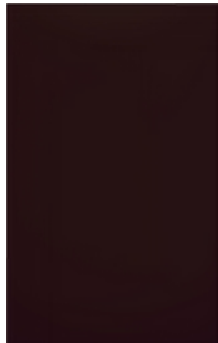

RAL 8017



RAL 6021



RAL 7030

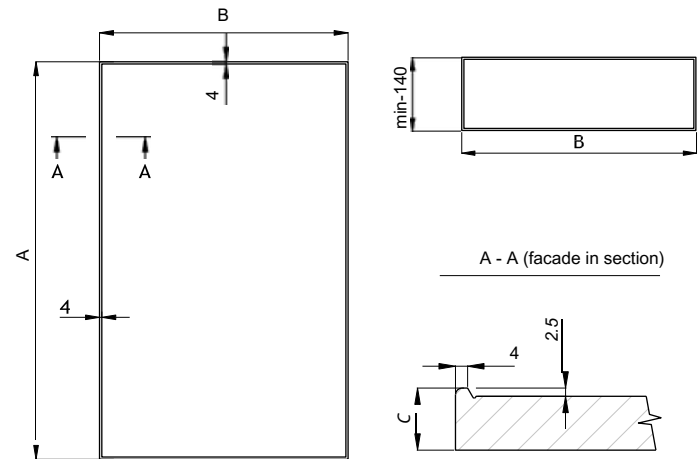

FACADES PAINTED



FACADES PAINTED

VISUALISATION MATERIALS:

- Colour: RAL 9023 Pearl dark grey
- Milling: Maura
- Worktop: Fenix NTM 0720 compact slab
Ingo Black core in 12 mm /art. 94172

MILLING MAURA



WCP 25



NCS S 1502Y50R



RAL 1012



WCP 230

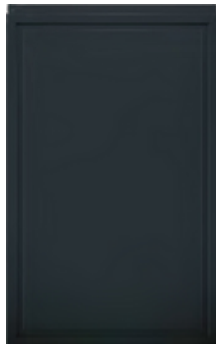

RAL 7031



RAL 6033

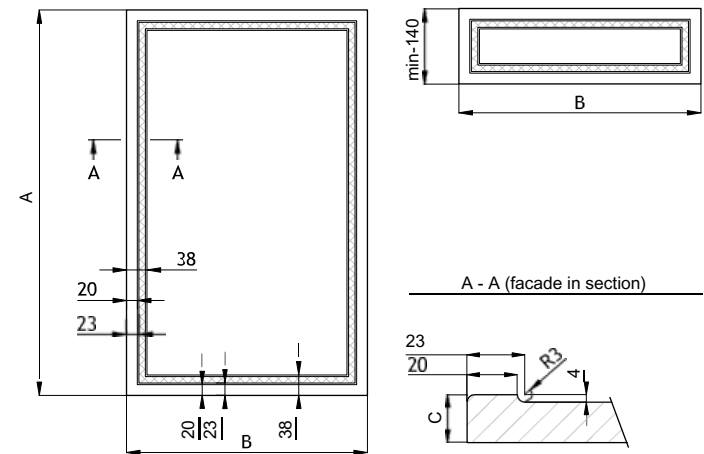

FACADES PAINTED

FACADES PAINTED

VISUALISATION MATERIALS:

- Colour:RAL7044 Grey silk
 - Milling: Nicole
- HandleMarellaM 15205.160 nickel polished /art. 46467
- Worktop EGGER F205 ST9 R3-1U Grigia Pietra 38 mm /art. 147901



MILLING NICOLE



WCP 133



WCP 148



RAL 6019



RAL 1035



NCS S 4005Y50R



RAL 1001

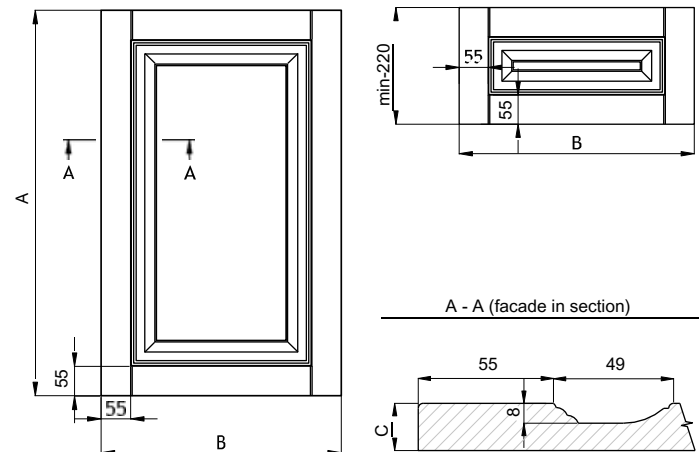

FACADES PAINTED

FACADES PAINTED

VISUALISATION MATERIALS:

- Colour:RAL7030Stone grey
 - Milling: Paola
- Arpa 3381LUNA worktop waterproof 40 mm /art. 147768
- Apron: Arpa 3381 LUNA



MILLING PAOLA



RAL 9018



RAL 5001

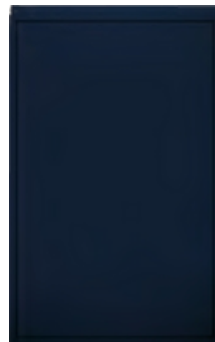

RAL 5009



NCS S 1505Y30R



NCS S 2005Y80R



NCS S 4005Y20R

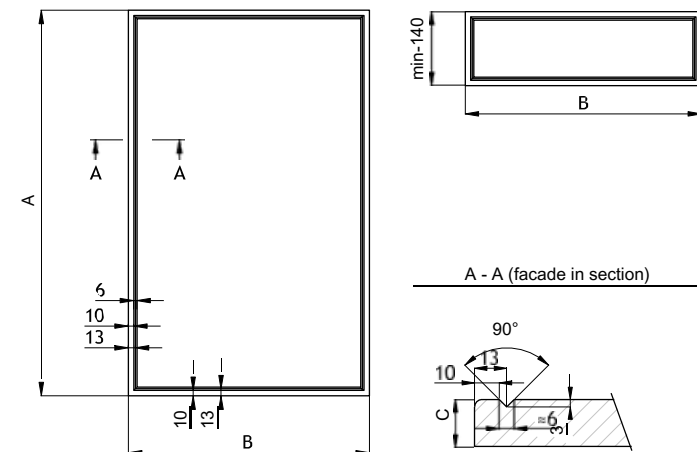

FACADES PAINTED

FACADES PAINTED

VISUALISATION MATERIALS:

- Colour: NCSS7000N, NCS S 1000N
- Milling: Frame
- Handle: Marella M15192.160 titanium/art. 69679



MILLING FRAME



WCP 294



NCS S 3010B30G



NCS S 0804Y30R

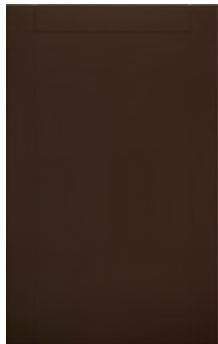

RAL 8025



RAL 9011



RAL 7005

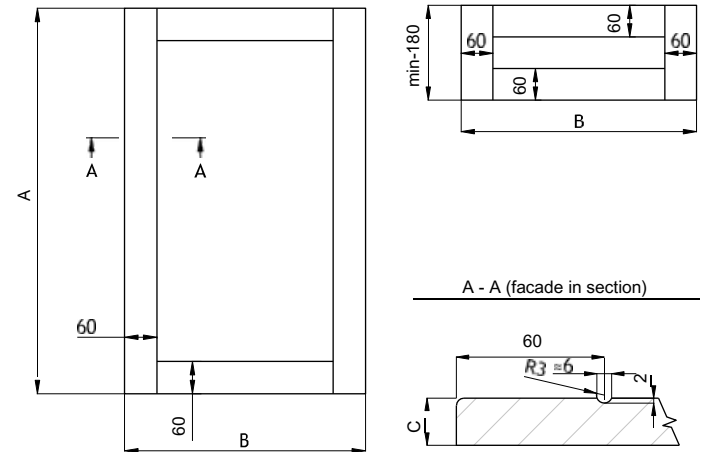

FACADES PAINTED



FACADES PAINTED

VISUALISATION MATERIALS:

- Colour:RAL6021Pale green
- Milling: Sigma
- MarellaCL24228.01.032 handle
blackmatt/art. 117515

MILLING SIGMA



RAL 5020



RAL 5007



RAL 6027



NCS S 7000N



RAL 9023



NCS S 1500N

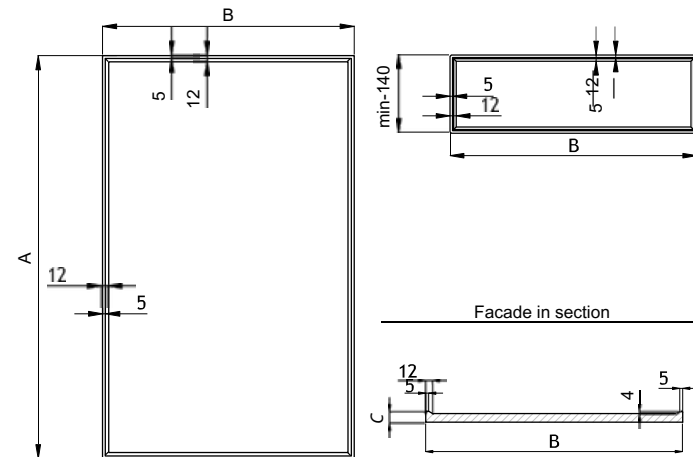

FACADES PAINTED

FACADES PAINTED

MATERIALS FOR
VISUALISATION:

- Colour: NCS S 1500N

- Milling: Simpl

- HandleMarella M15191.160
black matte /art. 69671

- Worktop Egger F117/ST76/R3-1U Ventura
stone black 38 mm /art. 147896

- Apron: Wall panel 2-sided Egger F117
ST76/F121 ST87 9.2 mm /art. 148177



MILLING SAMPLES



RAL 9010



WCP115



NCS S 2005Y40R



RAL 6034



RAL 7004



RAL 1019

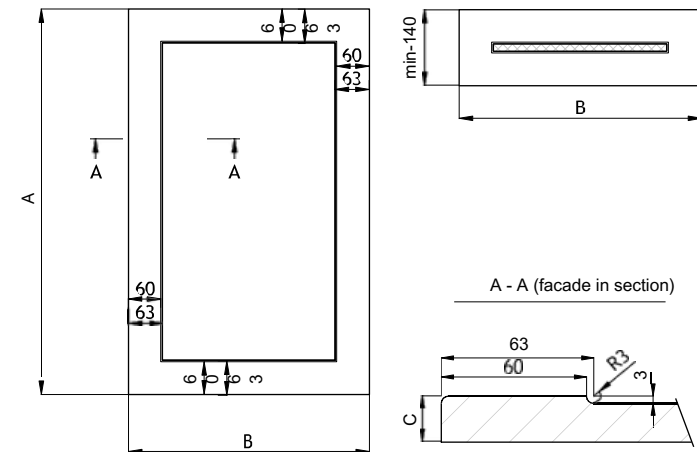

FACADES PAINTED



FACADES PAINTED

VISUALISATION MATERIALS:

- Colour:RAL 7042
- Milling:Without milling
- PenMarellaM15244.320nickel dark / art. 34619
 - WorktopKronospan K095SU Marmouth
Terrazzo Light 38 mm /art. 148264
 - Skinali (6 mm diamond on the glass) /art. 49756

WITHOUT MILLING



NCS S 1500N

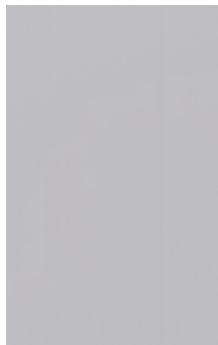

WCP 133



RAL 7042



RAL 7046

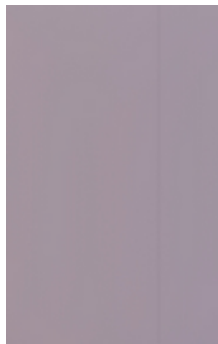

RAL 7036



RAL 7043



FACADES PAINTED



FACADES FILM

MATERIALS FOR
VISUALISATION:

- Facade: PVC film Cashmere.
NL7393(SERICA) /art. 49139
- Milling: Bruno
- Handle Marella M 15187.192
graphite /art. 37297
- Worktop: Neolith Pietra Grey matt
porcelain stoneware 12 mm /art.
120692
- Apron: Neolith Pietra porcelain stoneware
Grey matt 12 mm /art. 120692

MILLING BRUNO



NL 7473 (SERICA)
Light grey



NL 7393 (SERICA)
Cashmere



NL 7455 (SERICA)
Rain clouds



NL 7522 (SERICA)
Ice



VL 4258 (SERICA)
Combu green



RL 5989 (SERICA)
Marsala

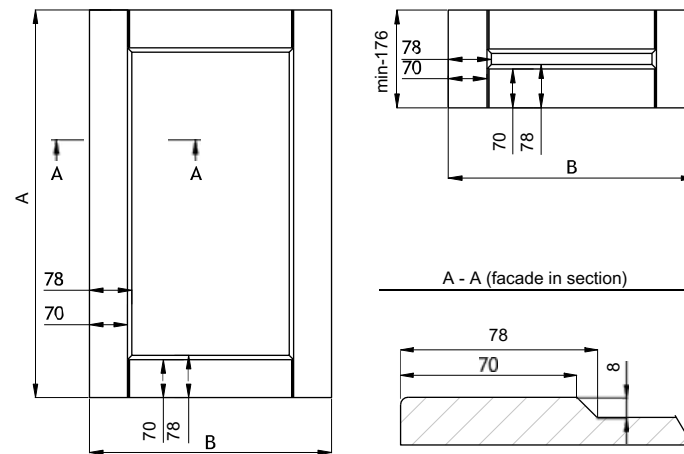

FACADES FILM

FACADES FILM

VISUALISATION MATERIALS:

- Facade:PVCfilm Ice
NL 7522 (SERICA) /art. 49140
- Milling: Inel
- Handle Marella M15205.160 nickel
polished /art. 46467
- Worktop: Fenix NTA 5000 compact slab Hamilton steel
black core 10 mm /art. 121680



MILLING INEL



YEM16-B9
Mussel structure



VL 4246 (SERICA)
Fjord



NL 7361 (SERICA)
Grey stone



BL 6221 (SERICA)
Indigo

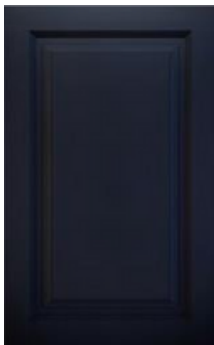

BL 6230 (SERICA)
Sea blue

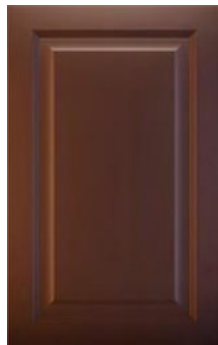

RL 5983 (SERICA)
Terracotta

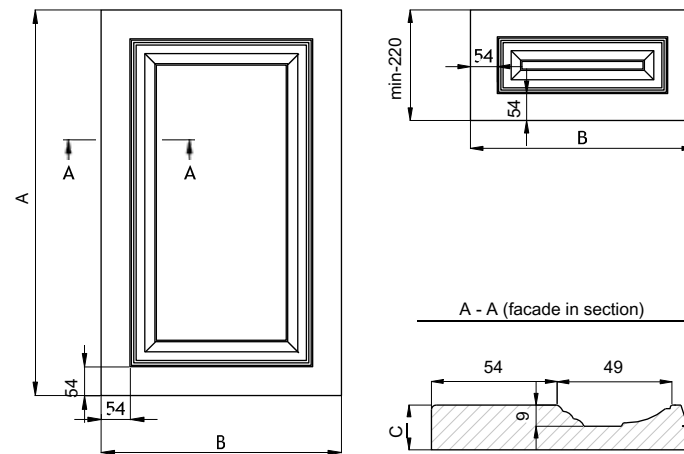

FACADES FILM

FACADES FILM

VISUALISATION MATERIALS:

- Facade: PVC film Rain clouds.
NL7455(SERICA) /art. 49131

- Milling: Cross

- Gola horizontal profile, L= 4000 mm,
type C, black brushed, Scilm /art. 58411

- Gola horizontal profile, L= 4000 mm,
type L, black brushed, Scilm / art. 58410

- Worktop: Fenix NTM 0720 compact slab
Ingo Black core in 12 mm colour /art. 94172

- Apron: Fenix NTM 0720 compact slab
Ingo Black core in 12 mm /art. 94172





FACADES FILM

VISUALISATION MATERIALS:

- Facade:PVCfilm Sea blue
BL6230(SERICA)/art. 49134
- Milling: Modern
- MarellahandleM 15191.160
titanium /art. 69675
- Egger F095/ST87/R3-1U worktop Marble
Siena grey 38 mm /art. 147894
- Apron: Egger F095 ST87/F041 ST15 2-sided
wall panel 9.2 mm /art. 148175

MILLING MODERN



KADR4-B9
Light grey structure



NCAB5-B9
Grey stone structure



F4242301
Sanremo sand



F4242489
Oak Riviera



F4242499
Oak One

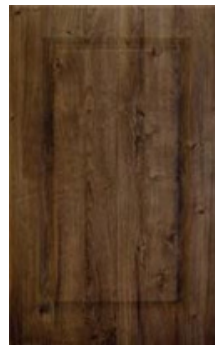

F4242526
Oak Ribbeck

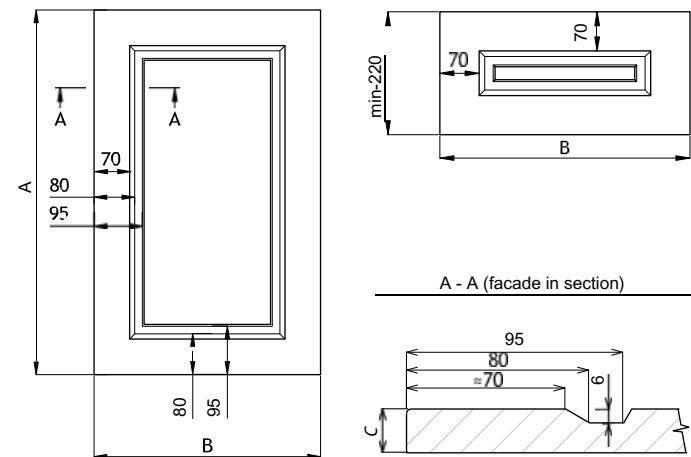

FACADES FILM

FACADES FILM

VISUALIZATION MATERIALS:

- Facade: PVC film Terracotta RL5983(SERICA) /art. 68450
- Milling: Frame with sample
- Handle VV 323/160, black, Turkey /art. 115583
- Worktop: Compact slab Arpa 0509 black core 12 mm /art. 94166



MILLING FRAME WITH SAMPLE

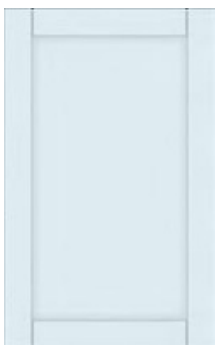

F4275001
Cold white



F4292031
Painted wood



D4151-001-M-0,45
Galaxy white



NL 7455 (SERICA)
Rain clouds



D6326-804-P5
Geraldine



AL 2156 (SERICA)
Foam

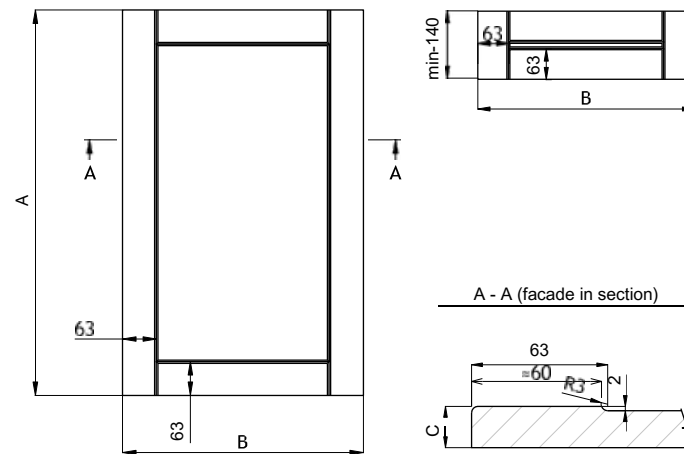

FACADES FILM



FACADES FILM

VISUALISATION MATERIALS:

- Facade: PVC film Fjord.
VL4246(SERICA) /art. 49127

- Milling: Fresco

- Handle Marella M 15244.320
nickel /art. 34617

- Worktop: Arpa 3447 Ker 38 mm

- Apron: Arpa 3447 Ker

MILLING FRESCO



NL 7473 (SERICA)
Light grey



NL 7522 (SERICA)
Ice



NL 7455 (SERICA)
Rain clouds



NCAB5-B9
Grey stone structure



VL 4246 (SERICA)
Fjord



VL 4258 (SERICA)
Kombu green

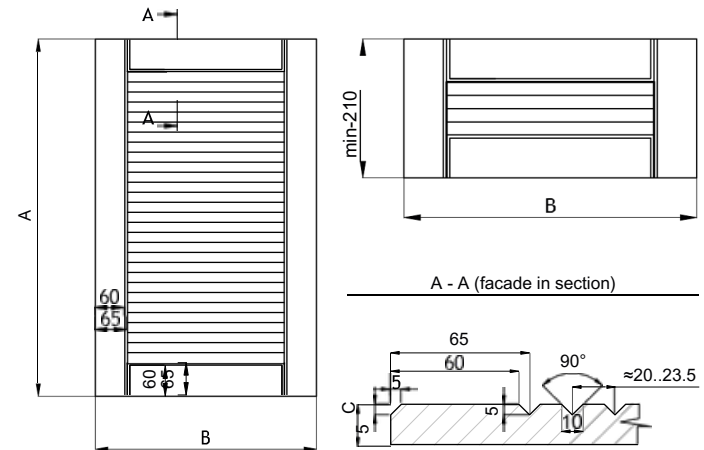

FACADES FILM

VISUALISATION MATERIALS:

- Facade: PVC film Combu green VL 4258 (SERICA) /art. 68448
 - Milling: Adele
- HandleMarella M 15191.160 black matt /art. 69671
- Egger F117/ST76/R3-1U worktop Ventura black 38 mm /art. 147896
- Apron: Egger F117 ST76/F121 ST87 2-sided wall panel 9.2 mm /art. 148177





FACADES FILM

VISUALIZATION MATERIALS:

- Facade: PVC film Sea blue BL 6230 (SERICA) /art. 49134
- Milling: Louis
- Handle Marella CL 24228.01.032 black matt /art. 117515

MILLING LOUIS



NL 7393 (SERICA)
Cashmere



D6326-804-P5
Geraldine



NL 7522 (SERICA)
Ice



VL 4246 (SERICA)
Fjord



NL 7455 (SERICA)
Rain clouds



BL 6221 (SERICA)
Indigo

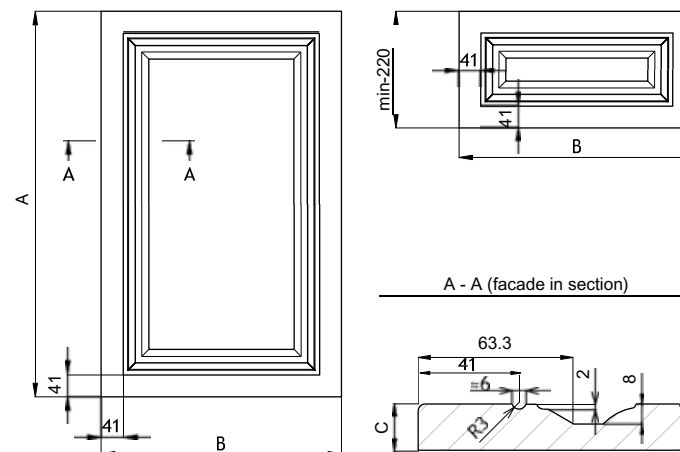

FACADES FILM

FACADES FILM

VISUALIZATION MATERIALS:

- Facade: PVCfilm Geraldine D6326-804-P5 /art. 67878
PVC filmMussel structure YEM16-B9 /art. 28382
 - Milling: Sul
- Handle Marella M 15194.160 graphite /art. 69687
- Pen Marella M 15194.320 graphite /art. 69690



MILLING SOUL



D4151-001-M-0,45
Galaxy white



VL 4246 (SERICA)
Fjord



D6326-804-P5
Geraldine



KADR4-B9
Light gray structure



YEM16-B9
Mussel structure



VL 4258 (SERICA)
Kombu green

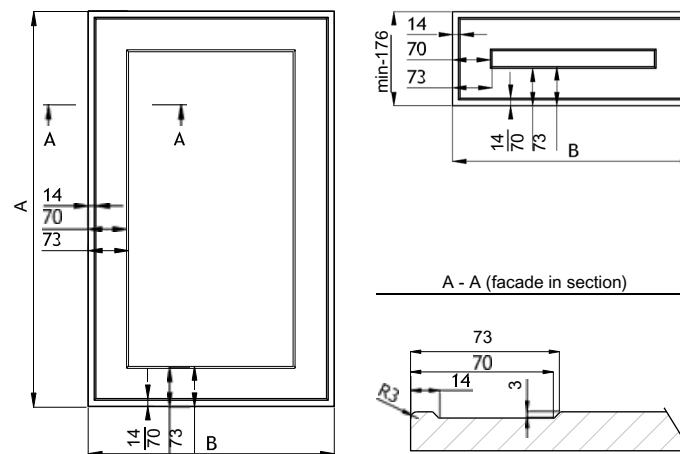

FACADES FILM

FACADES FILM

VISUALIZATION MATERIALS:

- Facade: PVC film Geraldine
D6326-804-P5/art. 67878

- Milling: Destini

- Handle Cosma M 12749.320
nickel brushed /art. 21844

- EGGER F205 ST9 R3-1U Grigia Pietra
38 mm worktop /art. 147901



MILLING DESTINI



RL 5983 (SERICA)
Terracotta



BL 6230 (SERICA)
Sea blue



F4242499
Oak One



F4242489
Riviera oak



NCAB5-B9
Gray stone structure



D6326-804-P5
Geraldine

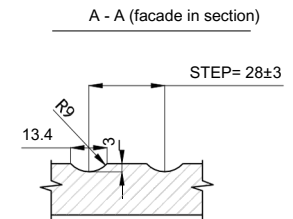
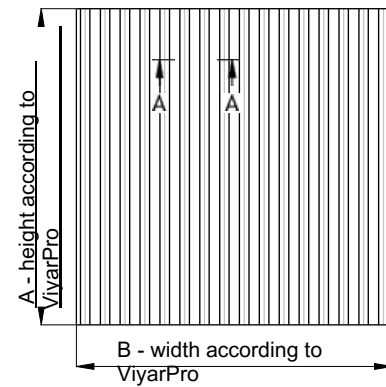

FACADES FILM

VISUALIZATION MATERIALS:

- Facade: PVC film Gray stone structure NCAB5-B9/art. 28385

- Milling: Corrado

- Handle Marella M 15244.320 nickel /art. 34617

- Luxeform W015-1 U worktop Black 38 mm /art. 149496



MILLING CORRADO



NL 7455 (SERICA)
Rain clouds



VL 4246 (SERICA)
Fjord

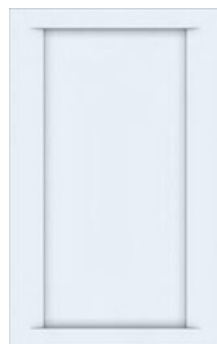

F4275001
Cold white



VL 4258 (SERICA)
Kombu green



F4242526
Oak Ribbeck



NL 7522 (SERICA)
Ice

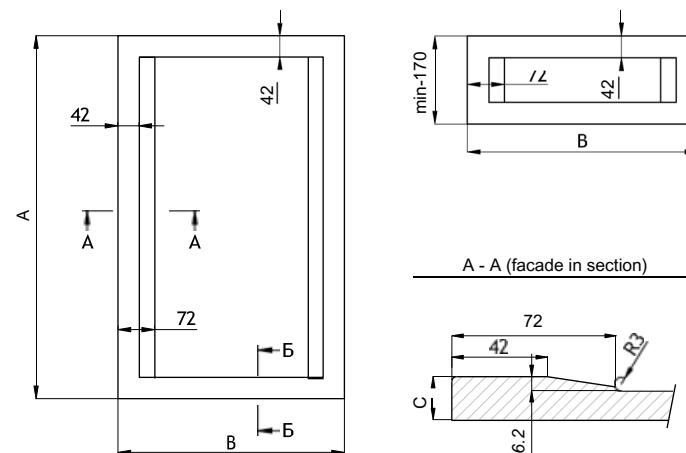

FACADES FILM

FACADES FILM

MATERIALS FOR VISUALIZATION:

- Facade: Magnoliagloss YEM-61PG

- Milling: X-Mystic

- Handle Marella M 24232.30
nickel / art. 69713



MILLING X-MYSTIC



NL 7473 (SERICA)
Light gray



VL 4246 (SERICA)
Fjord



BL 6230 (SERICA)
Sea blue



YEM16-B9
Mussel structure



D6326-804-P5
Geraldine



F4242489
Oak Riviera

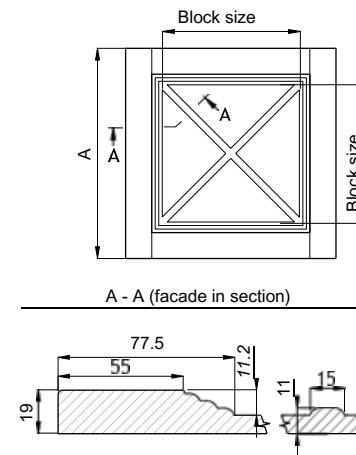
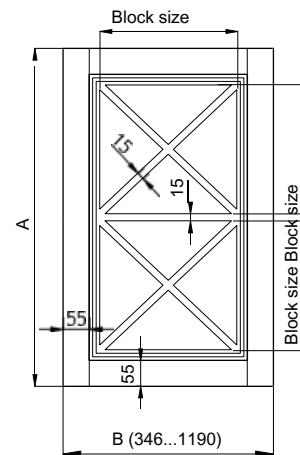

FACADES FILM

FACADES FILM

VISUALIZATION MATERIALS:

- Facade: PVC film Kombu green VL4258(SERICA)/art. 68448
 - Milling: X-Rosso
- Handle Marella M 24232.30 nickel /art. 69713



MILLING X-ROSSO



NL 7522 (SERICA)
Ice



RL 5989 (SERICA)
Marsala



VL 4258 (SERICA)
Kombu green



F4292031
Painted wood



D4151-001-M-0,45
White galaxy



NCAB4-B9
Cashmere structure

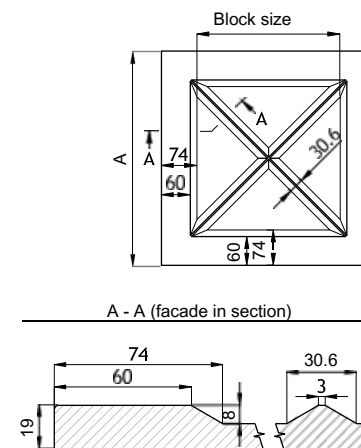
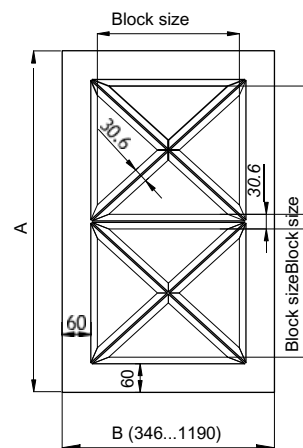

FACADES FILM

FACADES FILM

VISUALIZATION MATERIALS:

- Facade: PVCfilm Kombugreen VL4258(SERICA) /art. 68448
 - Milling: Customized
- Ferro Fiori M 0030.256 pen, black /art. 146949
- Tabletop EGGER F205 ST9 R3-1U Grigia Pietra 38 mm /art. 147901



MILLING INDIVIDUAL



RL 5983 (SERICA)
Terracotta



BL 6221 (SERICA)
Indigo



VL 4258 (SERICA)
Kombu green



NL 7361 (SERICA)
Gray stone



VL 4246 (SERICA)
Fjord



NCAB5-B9
Gray stone structure



FACADES HPL & FUSION

MATERIALS FROM VISUALIZATION:

- Facade:Fenix NTM 0718 LondonGray
- Worktop:GetaCore GCT 412 TerazzoArtico
- Apron: Wall panelchipboard 2-sided Ricci6019
AR/6133 AR 14 mm /art.126888

FENIX®





FUSION FENIX
NTM 0724
Bromine gray



FUSION FENIX
NTM 0750
Komodoro Green



FUSION FENIX
NTM 0720
Ingram Black

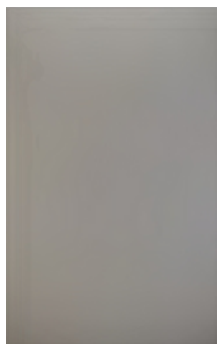

FENIX
NTM
0718
London gray



FENIX
NTM
0032
Kos
White



FENIX
NTM 0748
Arizona Beige



HPL- FACADES



HPL- FACADES

FACADES HPL & FUSION



FENIX
NTM 0751
Jaipur



FENIX
NTM 0766
Zante Gray



FENIX
BLOOM NTM 0773
Green Brack



FENIX
BLOOM NTM 0771
Light blue Naxos



FENIX
BLOOM NTM 0772
Yellow Kashmir



FENIX
BLOOM NTM 0770
Red Askia

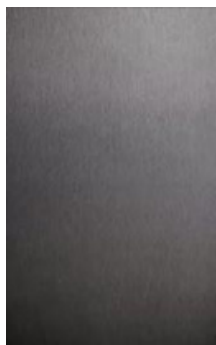

FENIX
NTA 5000
Hamilton steel

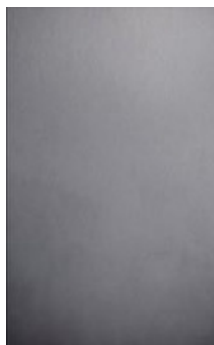

FENIX
NTA 5001
Silver Ducat

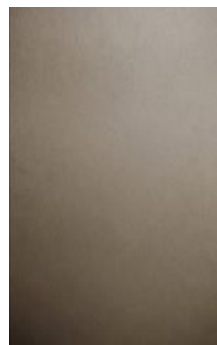

FENIX
NTA 5003
Gold Cortez



FENIX
NTM 0725
Ephesus gray



FENIX
NTM 0029
Male White



FENIX
NTM 0768
Stromboli gray



HPL-FACADES



HPL- FACADES

FACADES HPL & FUSION

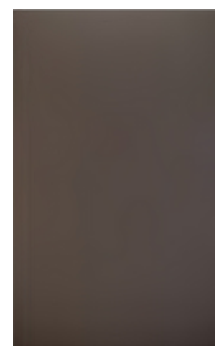

FENIX
NTM 0749
Orinoco Chocolate



FENIX
NTM 0752
Antrim gray



FENIX
NTM 0719
Luxor Beige



FENIX
NTM 0754
Fez Blue



FENIX
NTM 0030
Alaska White



FENIX
NTM 0717
Castoro Ottawa



FENIX
NTM 0767
Kolostai Beige



FENIX
NTM 0756
Skari gray



FENIX
NTM 2628
Doha Zinc

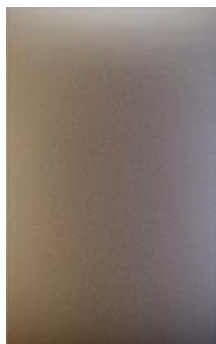

FENIX
NTM 2629
Doha Bronze

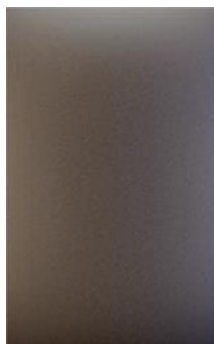

FENIX
NTM 2630
Doha Anthracite



FENIX
NTM 2638
Titanium



HPL- FACADES

FACADES HPL & FUSION

MATERIALS FOR VISUALIZATION:

• Facade: Arpa 0001 Luna, 3276 Luna

- Worktop Arpa 0738 Erre 19 mm / art. 111207



Arpa 



FUSION
ARPA 0001
Luna



FUSION ARPA 3276
Luna

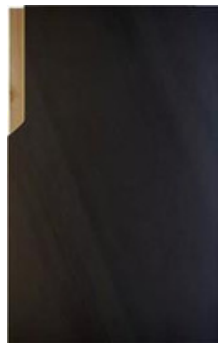

FUSION ARPA 3408
Losa



ARPA
4587
Aleve

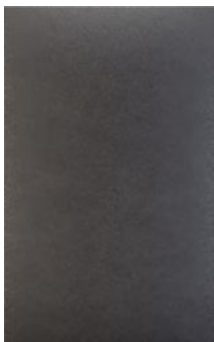

ARP
A
3329
Mika

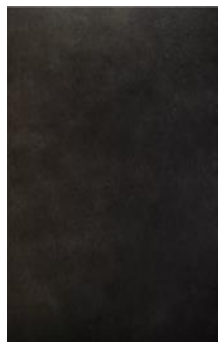

ARP
A
3279
Luna



HPL-FACADES



HPL- FACADES

FACADES HPL & FUSION

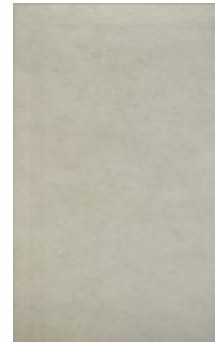

ARPA
3328
Mika

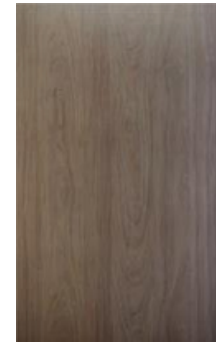

ARPA
4539
Aleve



ARPA
4604
Aleve

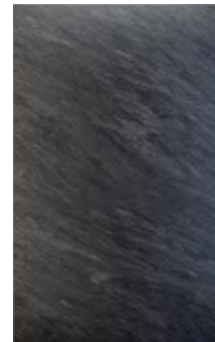

ARPA
3432
Losa

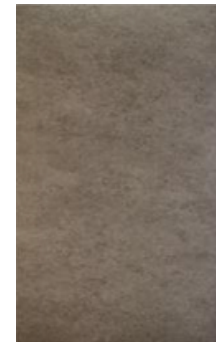

ARPA
3325
Mika



ARPA
3447
Ker



ARPA
4584
Aleve



ARPA
3431
Losa



ARPA
3395
Urban



ARP
A
3331
Luna



ARP
A
3324
Mika

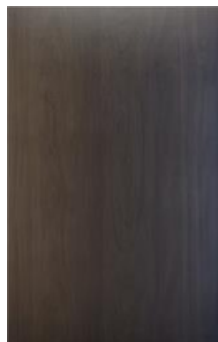

ARPA
4548
Aleve





HPL- FACADES

FACADES HPL & FUSION



ARPA
4574
Alevé

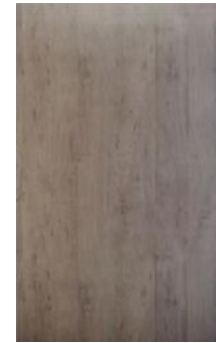

ARPA
4605
Alevé



ARPA
4585
Alevé



ARPA
0509
Luna



ARPA
3451
Ker



ARPA
4575
Larix



ARPA
BLOOM 0507
Ker

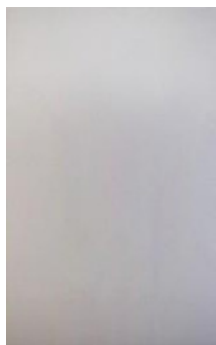

ARPA
BLOOM 0028
Ker



ARPA BLOOM
0700
Ker



ARPA
BLOOM 0738
Ker



ARPA
BLOOM 0776
Ker



ARPA BLOOM
0779
Ker



HPL- FACADES

FACADES BEL VISO GLASS

MATERIALS FOR VISUALIZATION:

•Aluminum profile R-11 black / art. 52004

•Graphite tinted glass 4 mm /art. 30049 •Ferro

Fiori M 0220.192 handle
black brush /art. 11482

Table top Egger H3133 ST12 R3-1U Davos
truffle oak 38 mm /art. 147934

Apron: chipboard wall panel 2-sided Ricci
6019 AR/6133 AR 14 mm /art. 126888





R-1 Silver polish.
Window glass
4 mm



R-1 Silver polished.
Bronze mirror 4 mm

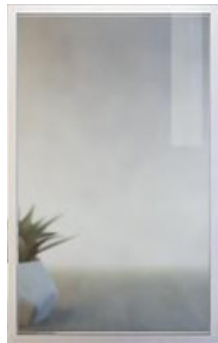

R-1 Silver brushed polish.
Glass satin white
4 mm



R-1 Black brushed polish.
Window glass
4 mm



R-1 Black brushed polish.
Trix transparent glass
4 mm

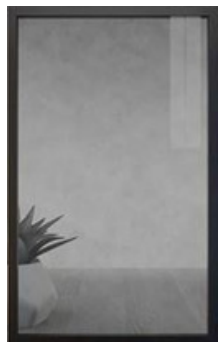

R-1 Black matte
Stopsol Classic
graphite glass 4 mm

R-1

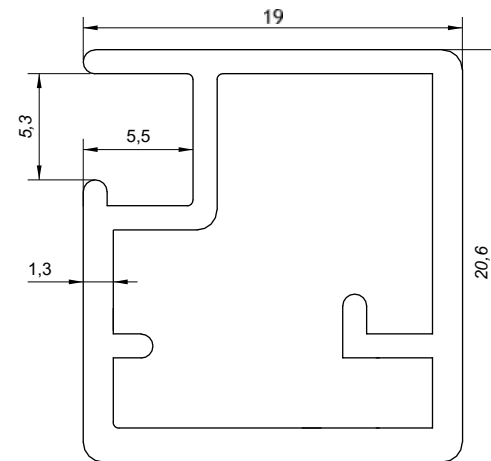

BEL VISO GLASS



FACADES BEL VISO GLASS

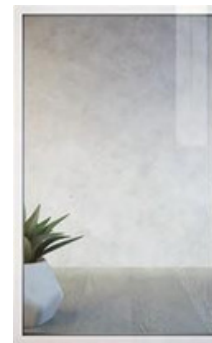

R-1 Silver polish.
Transparent window
glass
4 mm

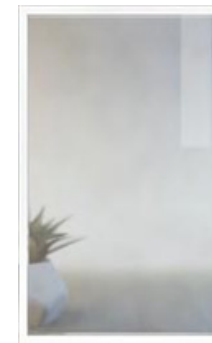

R-1 White matte
Satin white facade
glass 4 mm



R-1 White matte
Lacobel Pearl White
1013 4 mm



R-1 Bronze matte
Glass tinted bronze
4 mm



R-1 Bronze matte
glass satin bronze
4 mm



R-1 Graphite brushed
polish Glass Stopsol
Classic
Clear 4 mm

BEL VISO GLASS

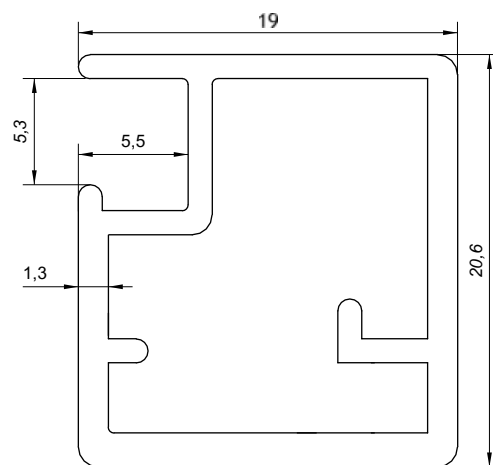

R-1

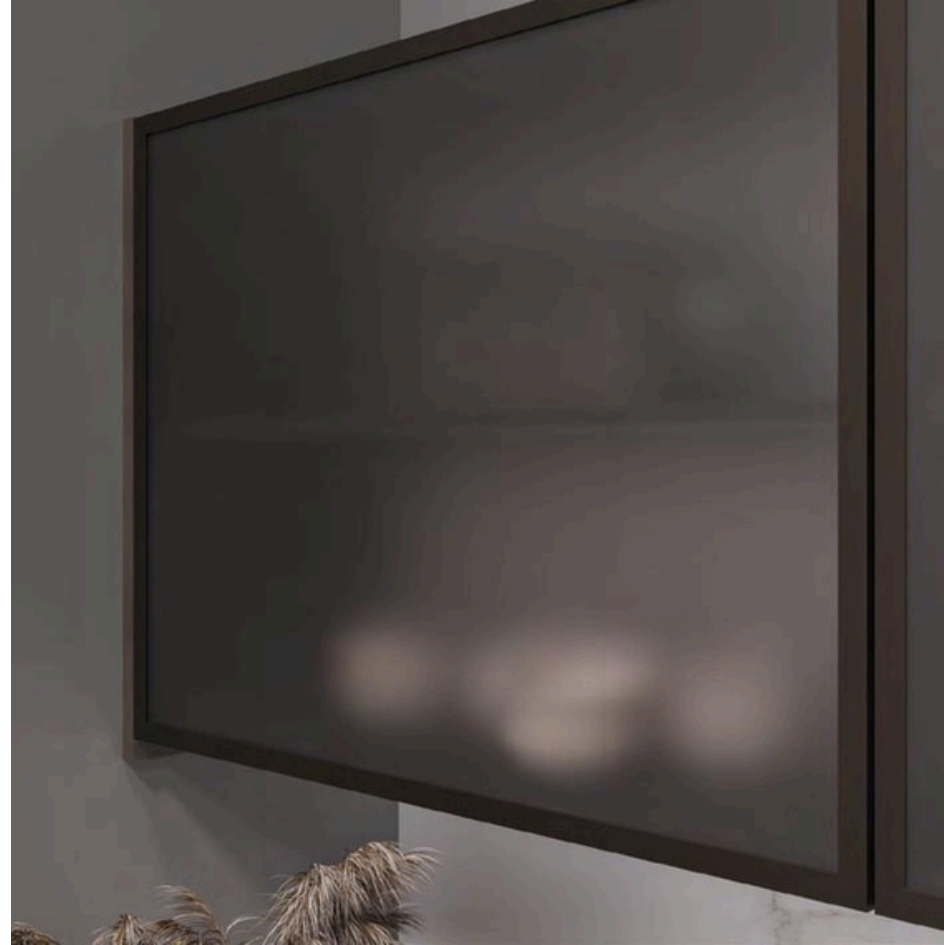

R-1 Gold polished
Glass Planibel Dark Grey 4 mm



R-1 Gold polish. Trix
transparent glass 4 mm



R-4 Graphite brushed
polish. Graphite tinted
glass 4 mm



R-1 Champagne
brushed Master
Ligne Saint Gobain
glass 4 mm

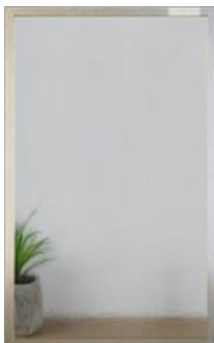

R-1 Nickel brushed
Master Thela Saint
Gobain glass 4 mm



R-4 Graphite brushed
polish. Diamond glass
4 mm

(R-) (4)

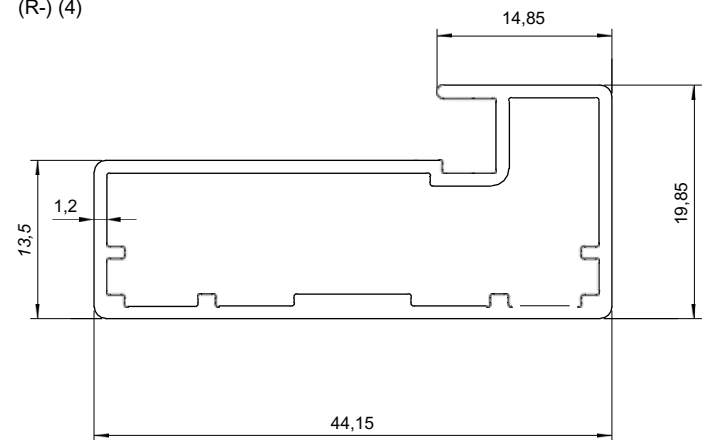

BEL VISO GLASS

FACADES BEL VISO GLASS



R-4 Silver matte Trix
clear glass
4 mm



R-4 Nickel
brushed Glass
Trix graphite
4 mm



R-4 Bronze matte
Trix bronze glass
4 mm



R-4 Black matte facade
glass
Flutes
sandblasted 4 mm

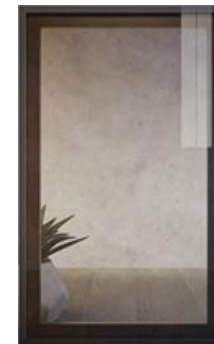

R-4 Black brushed polish.
Stopsol Classic
bronze glass 4 mm



R-4 Black brushed polish.
Diamond glass
4 mm

BEL VISO GLASS

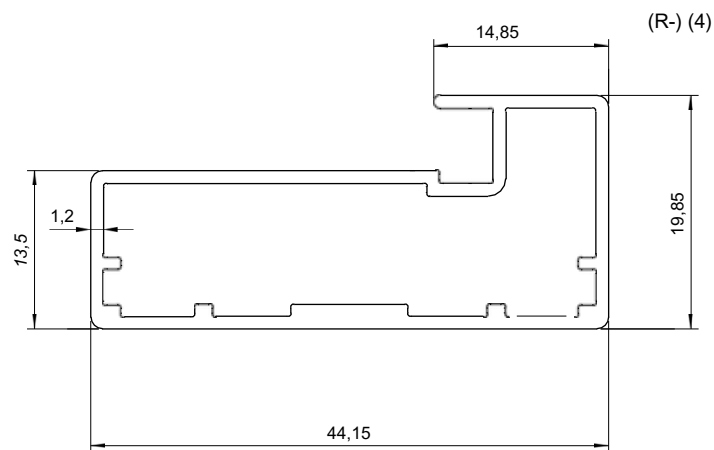



R-11 Silver
Glass diamond
4 mm, Oracal 076



R-11 Silver Mirror
satin 4 mm



R-11 Black Mirror
MORENA 4 mm



R-11 Black
Graphite tinted glass 4
mm, UV printing



R-11 Black
Mirror satin graphite
4 mm

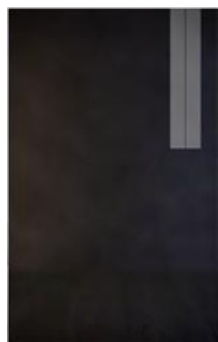

R-11 Silver
Lacobel Classic glass
Black 9005 4 mm

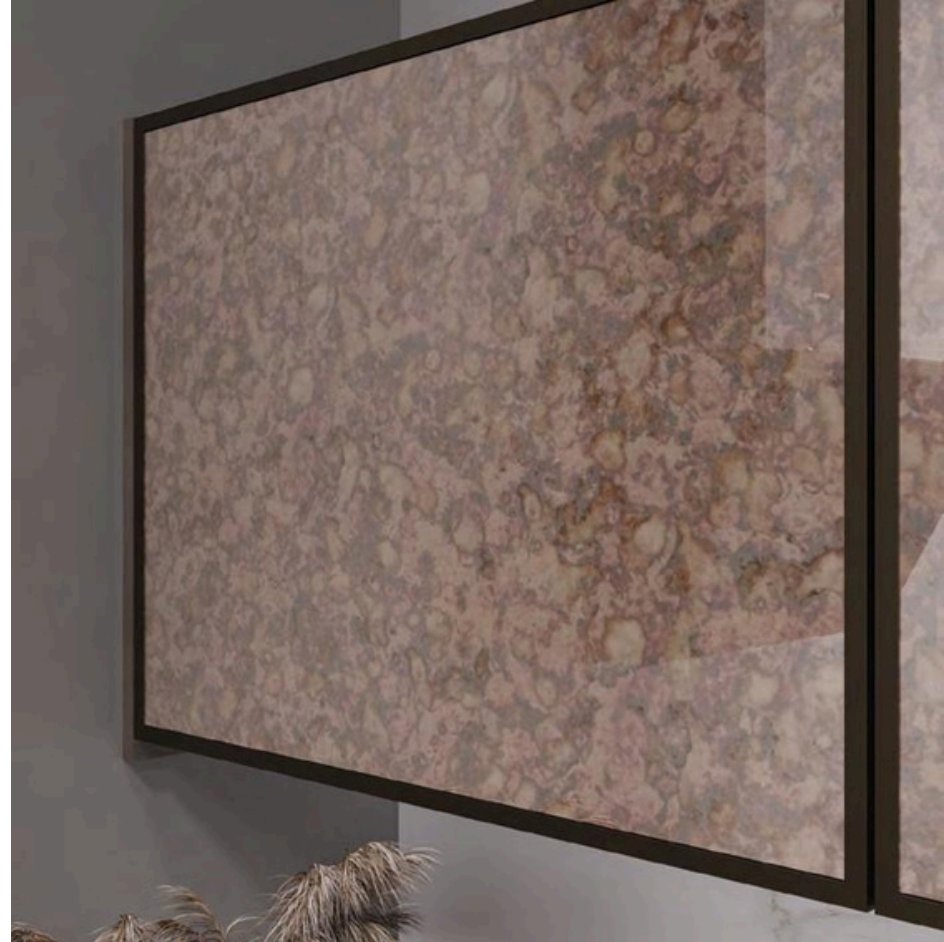

R-11

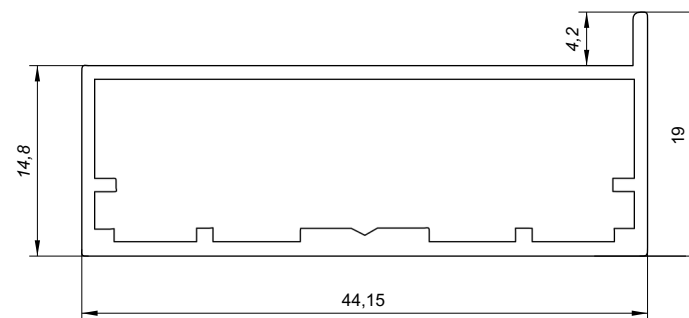

BEL VISO GLASS



FACADES BEL VISO GLASS



Noventa Graphite
brushed Glass tinted
graphite
4 mm



Oculito Gold
Two-sided mirror
gold 4 mm



Suave White
Window glass
4 mm



Noventa Black frosted glass
Planibel Dark Grey
4 mm



Oculito+ Entero
Black brushed Mirror
graphite 4 mm

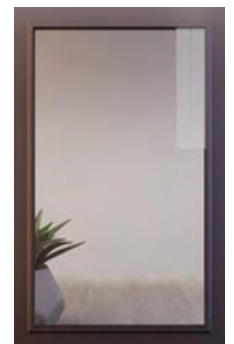

Suave Bronze matte
Tinted bronze glass
4 mm

BEL VISO GLASS

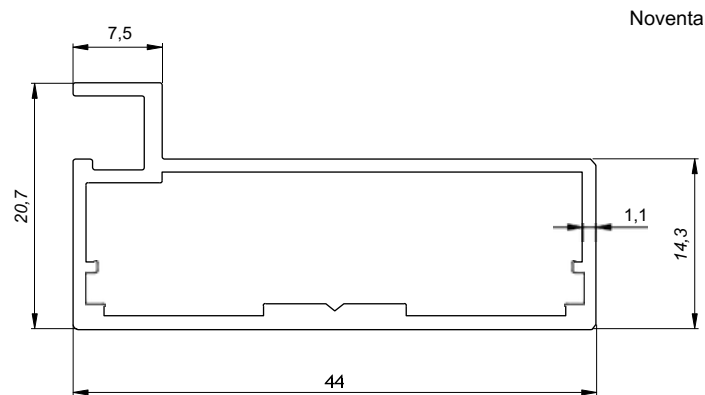

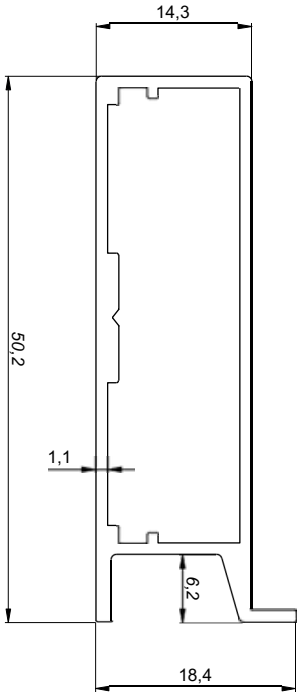

Oculto

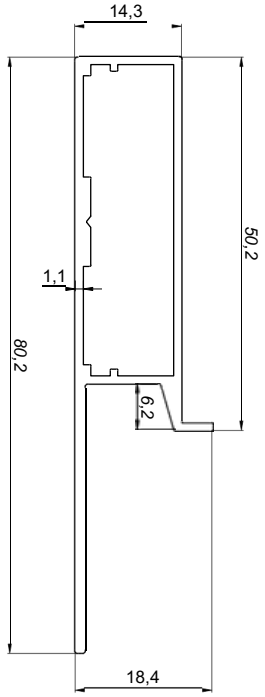

Entero

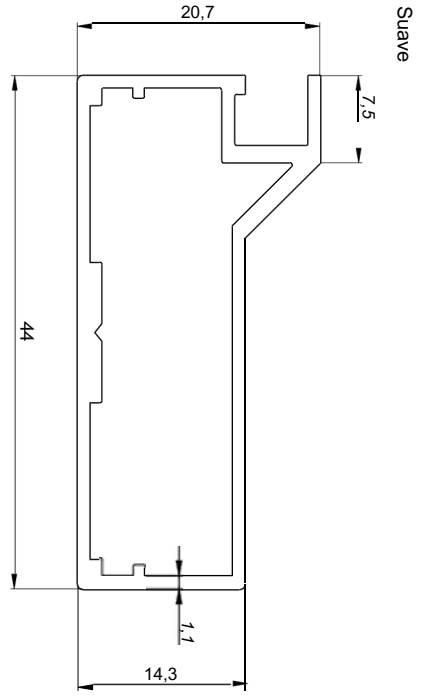

Suave

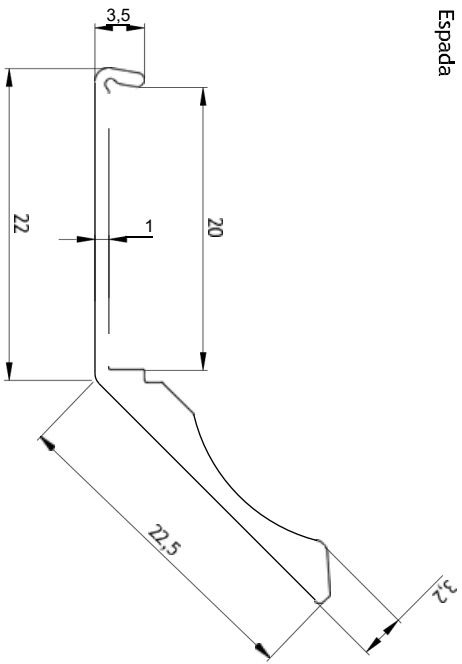

Espada

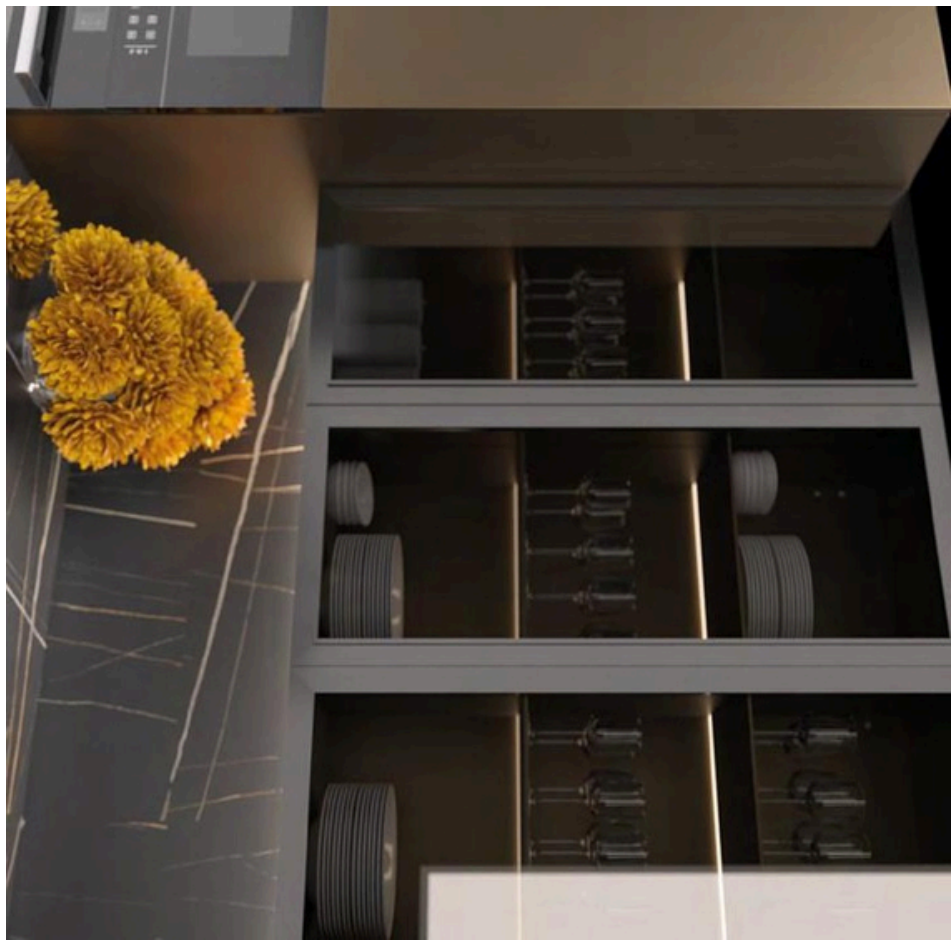

BEL VISO GLASS



FACADES BEL VISO GLASS



Ante 45°
Trix glass bronze
4 mm



Ante 45°
Glass
graphite
4 mm



Ante 45°
Tinted bronze glass
4 mm



Ante 90°
Glass Trix
graphite
4 mm



Ante 90°
Stopsol Classic glass
graphite 4 mm



Ante 90°
Glass Stopsol Classic
bronze 4 mm

BEL VISO GLASS

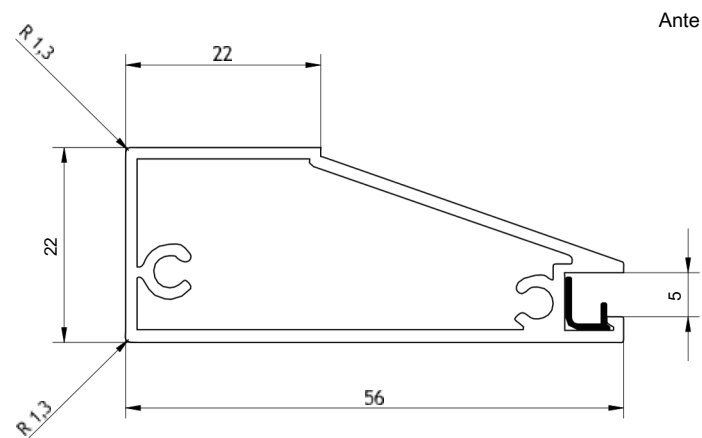

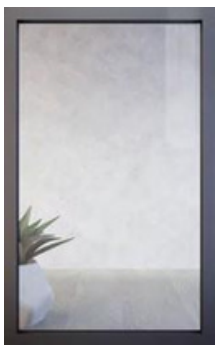

Ante Air black
Transparent window
glass
4 mm

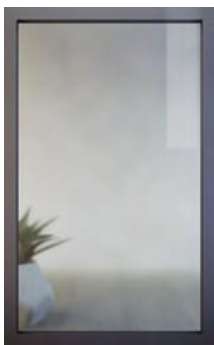

Ante Air black Satin
white facade glass
4 mm



Ante Air black
Planibel Dark Grey 4 mm
glass



Ante Air black
Planilaque Ultra white 9003
(Saint-Gobain) 4 mm glass



Ante Air black
Facade glass Matelac
Brown Light 1 236 4 mm



Ante Air black
Mirror Silver on
diamond 4 mm



Ante Air

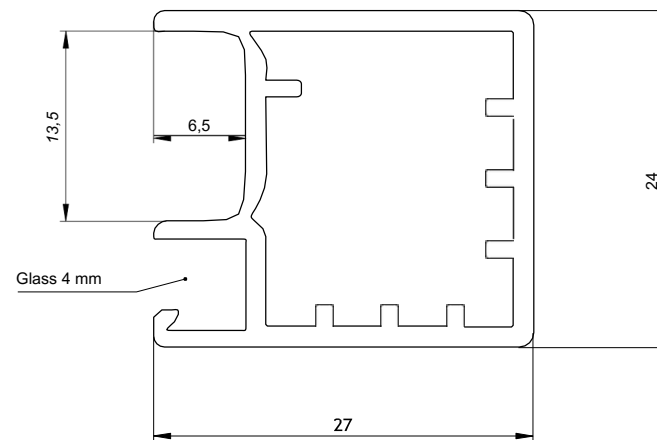

BEL VISO GLASS



FACADES BEL VISO GLASS



R11
Neolith Zaha Stone
6 mm



R11
Neolith Abu Dhabi White
6 mm

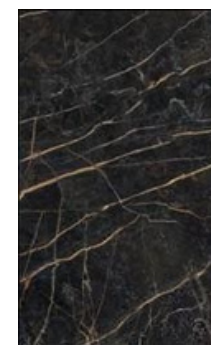

R11
Neolith Black Obsession
6 mm



R11
Inalco Umbra Marron
4 mm



R11
Inalco Vint Gris natural
4 mm

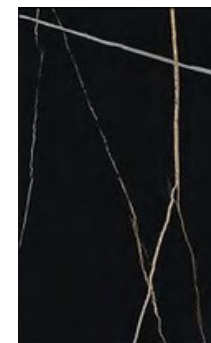

R11
Inalco Azalai Negro natural
4 mm

BEL VISO GLASS

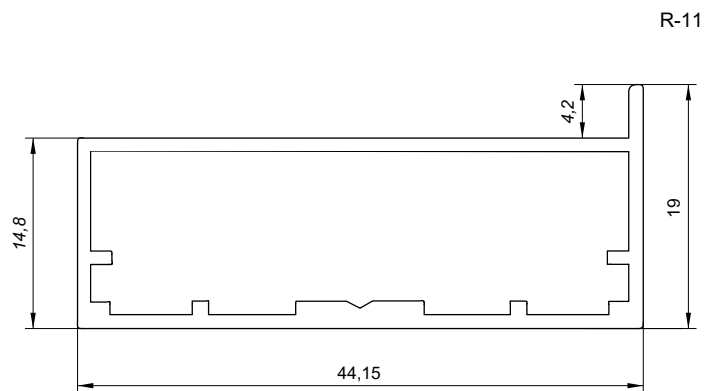



Oculito
Neolith Mont Blanc
6 mm



Oculito
Neolith ClasStone Calacatta
luxe ultrasoft 6 mm



Oculito
Neolith Layla Slate 6
mm



Oculito
Inalco Atalaia Super
Blanco 4 mm

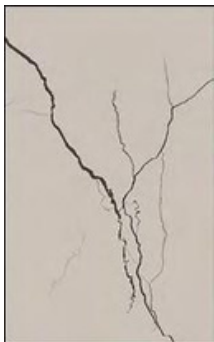

Oculito
Inalco Brazza Crema 4
mm

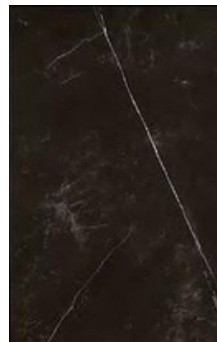

Oculito
Inalco Storm Negro
4 mm

Oculito

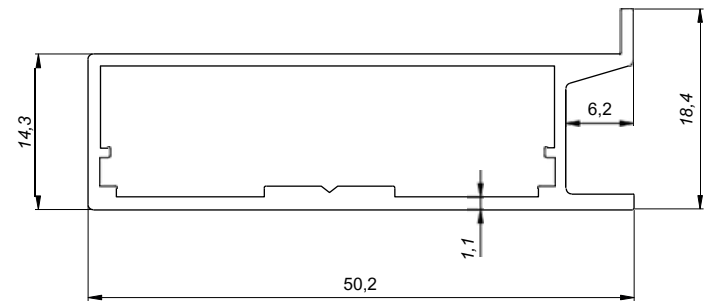

BEL VISO GLASS

FACADES ACRYLIC

VISUALIZATION MATERIALS:

- Facade: Rauvisio Crystal V2778Bright
white Gloss / art.24036Rauvisio
Crystal 1969L Marble Romano/art.
51548
- Marella M 15194.160 handle
graphite /art. 69687
- Handle Marella M 15194.320
graphite /art. 69690



Rauvisio Crystal
2409L
Atlantico Gloss



Rauvisio Crystal
1969L
Gloss Romano marble



Rauvisio Crystal
1721L
Mirror



Rauvisio Crystal
V2778
Gloss Bright white



Rauvisio Crystal
73703
Ivory gloss

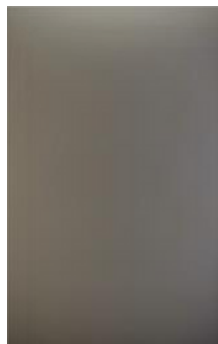

Rauvisio Crystal
2109L
Titanio Matte



ACRYLIC FACADES



ACRYLIC FACADES

FACADES ACRYLIC

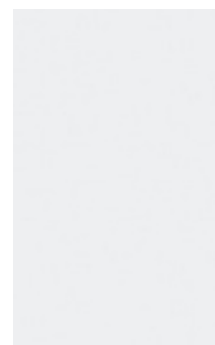

Rauvisio Crystal
2587L
Oro Bianco



Rauvisio Crystal
1700L
Matte Mint



Rauvisio Crystal
1696L
Matte Bright white



Rauvisio Crystal
1687L
Glossy gray



Rauvisio Crystal
1698L
Matte Ivory



Rauvisio Crystal
1702L
Matte Smoky



Rauvisio Crystal
1703L
Matte gray



Rauvisio Crystal
1976L
Glossy Bleached wood



Rauvisio Crystal
1697L
Matte White



Rauvisio Crystal
1911L
Matte light gray

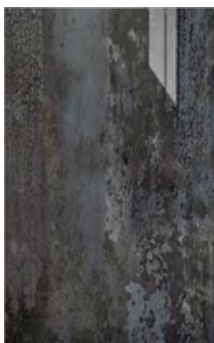

Rauvisio Crystal
1975L
Glossy Burnt wood



Rauvisio Crystal
1974L
Glossy Antique wood



ACRYLIC FACADES



ACRYLIC FACADES

FACADES ACRYLIC

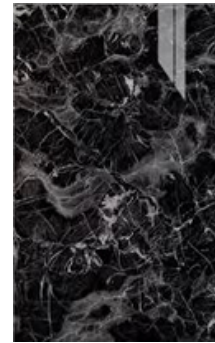

Rauvisio Crystal
1971L
Gloss Marble Black



Rauvisio Crystal
2015L
Piano Gloss Black



Rauvisio Crystal
1968L
Tuscany marble high gloss



Rauvisio Crystal
1910L
Light gray gloss

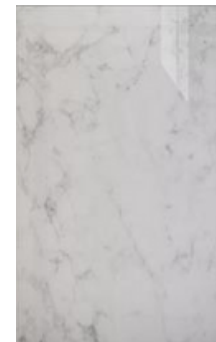

Rauvisio Crystal
1970L
Gloss Marble White



Rauvisio Crystal
V2892
White gloss



Rauvisio Crystal
1684L
Mint gloss



Rauvisio Crystal
2407L
Laguna Gloss



Rauvisio Crystal
1974L
Antique wood

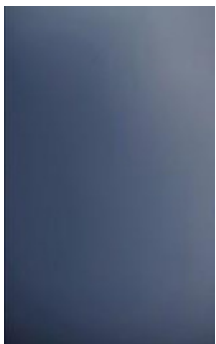

Rauvisio Crystal
2410L
Atlantico Matte



Rauvisio Crystal
2408L
Laguna Matte



Rauvisio Crystal
1686L
Smoky Gloss

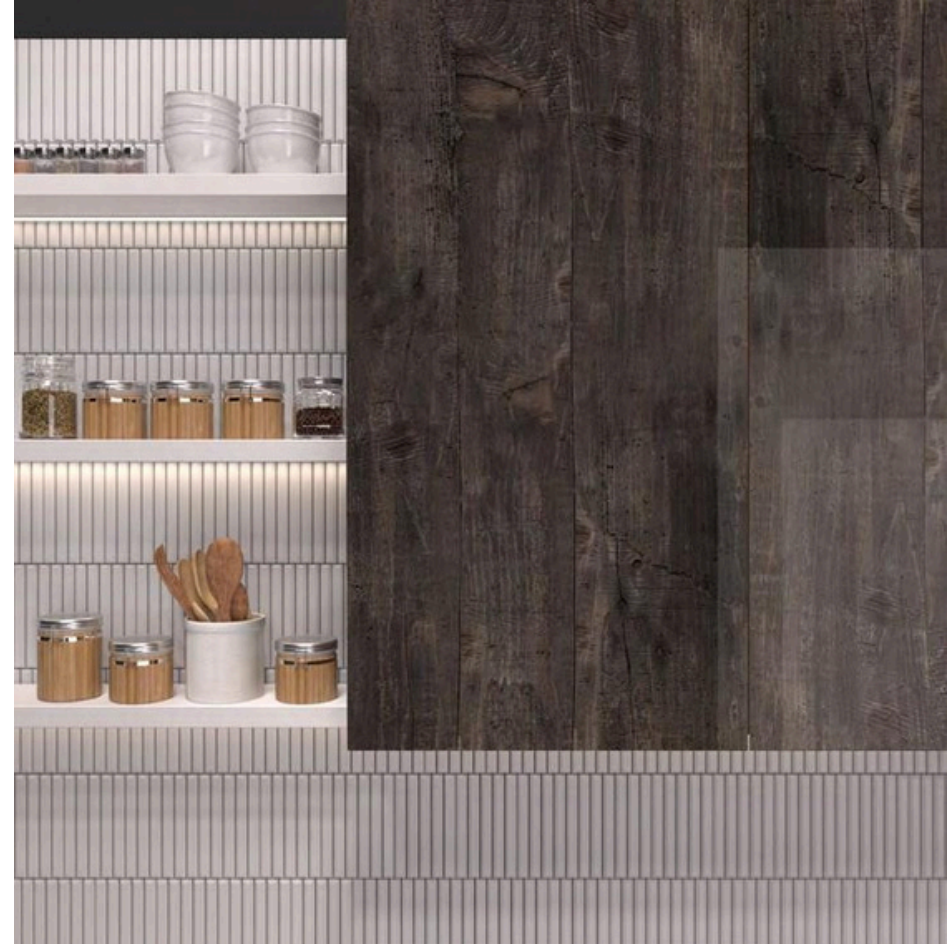

ACRYLIC FACADES